

INTRODUCTION TO COMSOL Multiphysics

Introduction to COMSOL Multiphysics

© 1998–2015 COMSOL

Protected by U.S. Patents listed on www.comsol.com/patents, and U.S. Patents 7,519,518; 7,596,474; 7,623,991; 8,457,932; 8,954,302; 9,098,106; and 9,146,652. Patents pending.

This Documentation and the Programs described herein are furnished under the COMSOL Software License Agreement (www.comsol.com/comsol-license-agreement) and may be used or copied only under the terms of the license agreement.

COMSOL, COMSOL Multiphysics, Capture the Concept, COMSOL Desktop, LiveLink, and COMSOL Server are either registered trademarks or trademarks of COMSOL AB. All other trademarks are the property of their respective owners, and COMSOL AB and its subsidiaries and products are not affiliated with, endorsed by, sponsored by, or supported by those trademark owners. For a list of such trademark owners, see www.comsol.com/trademarks.

Version: COMSOL 5.2

Contact Information

Visit the Contact COMSOL page at www.comsol.com/contact to submit general inquiries, contact Technical Support, or search for an address and phone number. You can also visit the Worldwide Sales Offices page at www.comsol.com/contact/offices for address and contact information.

If you need to contact Support, an online request form is located at the COMSOL Access page at www.comsol.com/support/case. Other useful links include:

- Support Center: www.comsol.com/support
- Product Download: www.comsol.com/product-download
- Product Updates: www.comsol.com/support/updates
- COMSOL Blog: www.comsol.com/blogs
- Discussion Forum: www.comsol.com/community
- Events: www.comsol.com/events
- COMSOL Video Gallery: www.comsol.com/video
- Support Knowledge Base: www.comsol.com/support/knowledgebase

Part number: CM010004

Contents

Introduction	5
COMSOL Desktop®	6
Example 1: Structural Analysis of a Wrench.	30
Example 2: The Busbar—A Multiphysics Model	53
Advanced Topics	94
Parameters, Functions, Variables and Couplings.	94
Material Properties and Material Libraries.	98
Adding Meshes.	100
Adding Physics	102
Parametric Sweeps.	123
Parallel Computing.	132
Appendix A—Building a Geometry.	136
Appendix B—Keyboard and Mouse Shortcuts	151
Appendix C—Language Elements and Reserved Names.	155
Appendix D—File Formats.	168
Appendix E—Connecting with LiveLink™ Add-Ons	174

Introduction

Read this book if you are new to COMSOL Multiphysics®. It provides an overview of the COMSOL® environment with examples that show you how to use the COMSOL Desktop® user interface and the Model Builder. It also provides a quick introduction to creating applications using the Application Builder.

If you have not yet installed the software, install it now according to the instructions at www.comsol.com/product-download.

In addition to this book, an extensive documentation set is available after installation. Tutorials can be found throughout the COMSOL website, including in the Video Gallery at www.comsol.com/videos and in the COMSOL Blog at www.comsol.com/blogs.

QUICK ACCESS TOOLBAR—Use these buttons for access to functionality such as file open/save, undo/redo, copy/paste, and delete.

RIBBON—The ribbon tabs have buttons and drop-down lists for controlling all steps of the modeling process.

APPLICATION BUILDER—Click this button to switch to the Application Builder and start building an application based on your model.

MODEL BUILDER TOOLBAR

MODEL TREE—The model tree gives an overview of the model and all the functionality and operations needed for building and solving a model as well as processing the results.

MODEL BUILDER—The Model Builder window with its model tree and the associated toolbar buttons gives you an overview of the model. The modeling process can be controlled from context-sensitive menus accessed by right-clicking a node.

SETTINGS WINDOW—Click any node in the model tree to see its associated Settings window displayed next to the Model Builder.

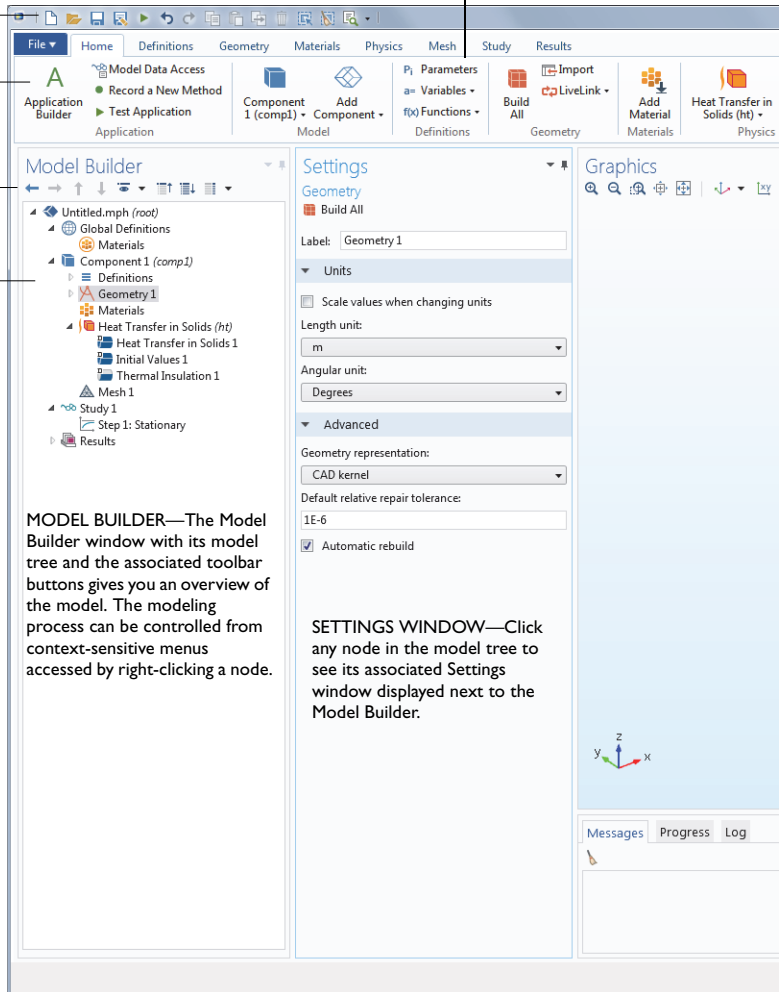

GRAPHICS WINDOW TOOLBAR

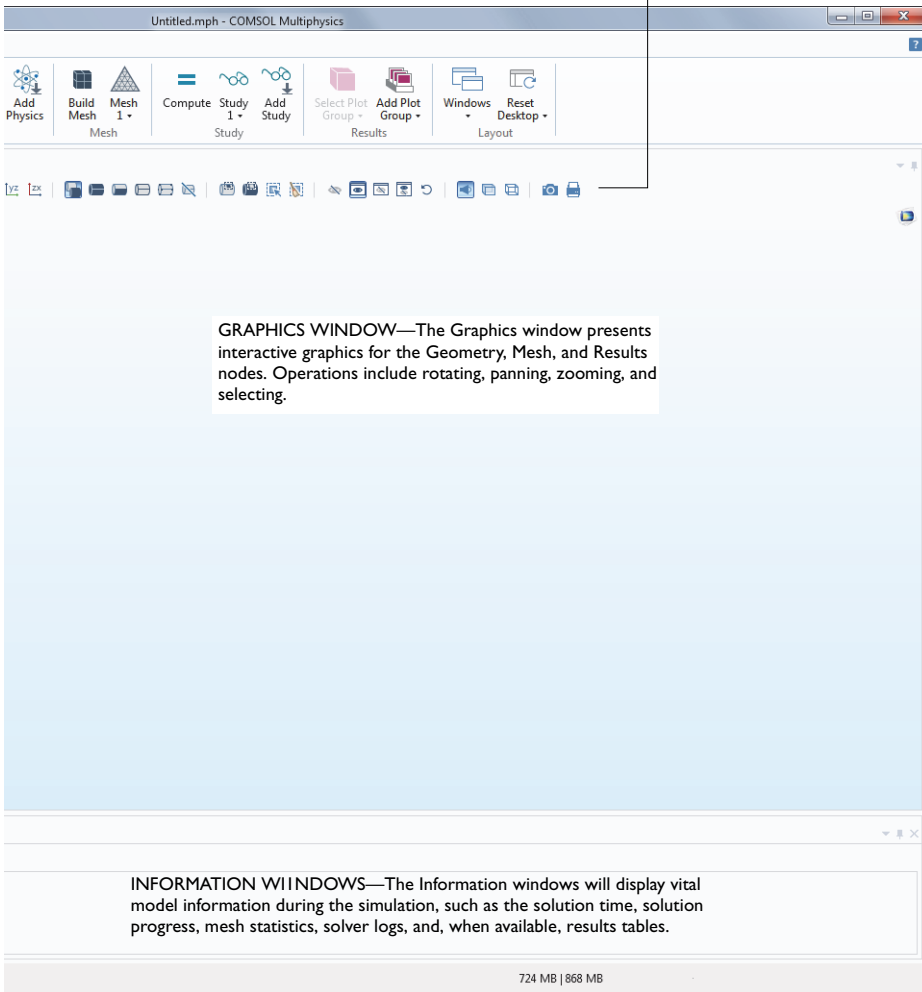

The screenshot on the previous pages is what you will see when you first start modeling in COMSOL Multiphysics using the Model Builder. COMSOL Desktop[®] provides a complete and integrated environment for physics modeling and simulation as well as application design, providing you with the tools necessary to build a user-friendly interface for your models. You can customize the desktop to your own needs. The windows can be resized, moved, docked, and detached. Any changes you make to the layout will be saved when you close the session and available again the next time you open COMSOL Multiphysics. As you build your model, additional windows and widgets will be added. (See page 24 for an example of a more developed desktop.) Among the available windows and user interface components are the following:

Quick Access Toolbar

The Quick Access Toolbar gives access to functionality such as Open, Save, Undo, Redo, Copy, Paste, and Delete. You can customize its content from the Customize Quick Access Toolbar list.

Ribbon

The ribbon at the top of the desktop gives access to commands used to complete most modeling tasks. The ribbon is only available in the Windows[®] version of the COMSOL Desktop environment and is replaced by menus and toolbars in the OS X and Linux[®] versions. Click the Application Builder button to switch from the Model Builder to the Application Builder and start building an application based on your model.

Settings Window

This is the main window for entering all of the specifications of the model including the dimensions of the geometry, properties of the materials, boundary conditions and initial conditions, and any other information that the solver will

need to carry out the simulation. The picture below shows the Settings window for the Geometry node.

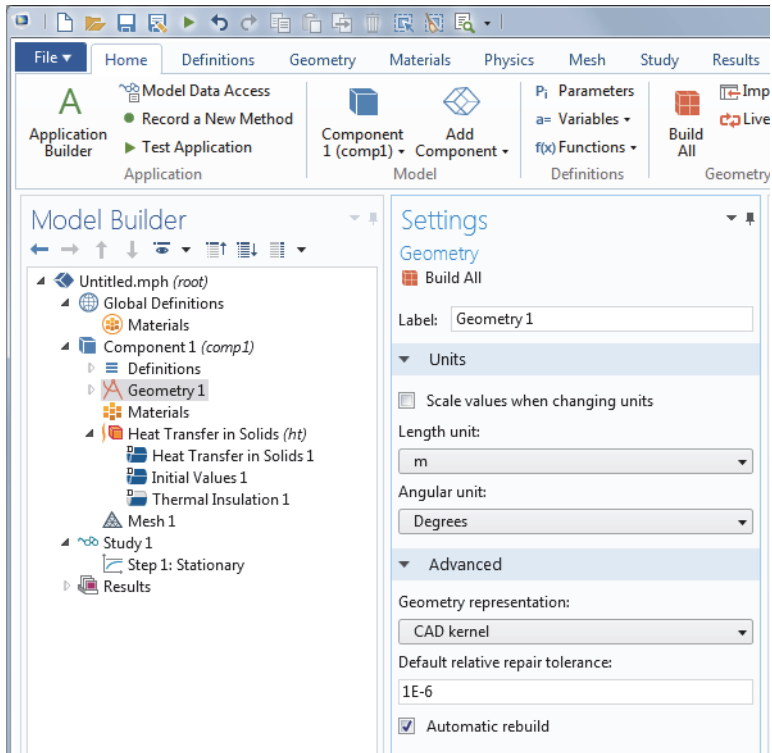

Plot Windows

These are the windows for graphical output. In addition to the Graphics window, Plot windows are used for visualizing results. Several Plot windows can be used to show multiple results simultaneously. A special case is the Convergence Plot window, an automatically generated Plot window that displays a graphical indication of the convergence of the solution process while a model is running.

Information Windows

These are the windows for non-graphical information. They include:

- Messages: Various information about the current COMSOL session is displayed in this window.
- Progress: Progress information from the solver in addition to stop buttons.
- Log: Information from the solver such as number of degrees of freedom, solution time, and solver iteration data.

- Table: Numerical data in table format as defined in the Results branch.
- External Process: Provides a control panel for cluster, cloud, and batch jobs.

Other Windows

- Add Material and the Material Browser: Access the material property libraries. The Material Browser enables editing of material properties.
- Selection List: A list of geometry objects, domains, boundaries, edges, and points that are currently available for selection.

The Windows drop-down list in the Home tab of the ribbon gives you access to all COMSOL Desktop windows. (On OS X and Linux[®], you will find this in the Windows menu.)

Progress Bar with Cancel Button

The Progress Bar with a button for canceling the current computation, if any, is located in the lower right-hand corner of the COMSOL Desktop interface.

Dynamic Help

The Help window provides context-dependent help texts about windows and model tree nodes. If you have the Help window open in your desktop (by typing F1, for example), you will get dynamic help (in English only) when you click a node or a window. From the Help window you can search for other topics such as menu items.

The Model Builder and the Application Builder

The two main components of the COMSOL Desktop environment are the Model Builder and the Application Builder.

The Model Builder is the tool where you define the model and its components: how to solve it, the analysis of results, and the reports. You do that by building a model tree. The model tree reflects the underlying data structure, the model object, which stores the state of the model including settings for: geometry, mesh, physics, boundary conditions, studies, solvers, postprocessing, and visualizations.

The Application Builder allows you to quickly create an application with a specialized user interface that is easy to use. An application is based on a model created with the Model Builder. The Application Builder provides two important tools for creating applications: The Form editor and the Method editor. In addition, an application can have a menu bar or a ribbon. The Form editor includes drag-and-drop capabilities for easily accessing and including user

interface components such as input fields, graphics windows, and buttons. The Method editor is a programming environment that allows you to modify the model represented by the model object data structure.

This book, *Introduction to COMSOL Multiphysics*, gives a detailed introduction to using the Model Builder and a quick introduction to the Application Builder. For detailed information on how to use the Application Builder, see *Introduction to Application Builder*.

Running Applications and COMSOL Server

The Application Builder is included in the Windows® version of COMSOL Multiphysics. With a COMSOL Multiphysics license, applications can be run from the COMSOL Desktop. With a COMSOL Server license, applications can be run in major web browsers on a variety of operating systems and hardware platforms. In addition, you can run applications by connecting to COMSOL Server with an easy-to-install COMSOL Client for Windows®.

The COMSOL Client for Windows® allows a user to run applications that require a LiveLink™ product for CAD.

Running applications in a web browser does not require any installation and no web browser plug-ins are needed. Running an application in a web browser supports interactive graphics in 1D, 2D, and 3D. In a web browser, graphics rendering in 3D is based on WebGL™ technology which comes included with all major web browsers.

To create an application based on your model, use the Application Builder, accessible from the Home tab in the ribbon.

For more information on creating a COMSOL application, refer to the section “Creating an Application using the New Form Wizard” on page 82 and the book *Introduction to Application Builder*.

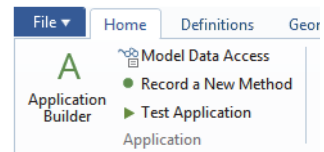

Preferences

Preferences are settings that affect the modeling environment. Most are persistent between modeling sessions, but some are saved with the model. You access Preferences from the File menu.

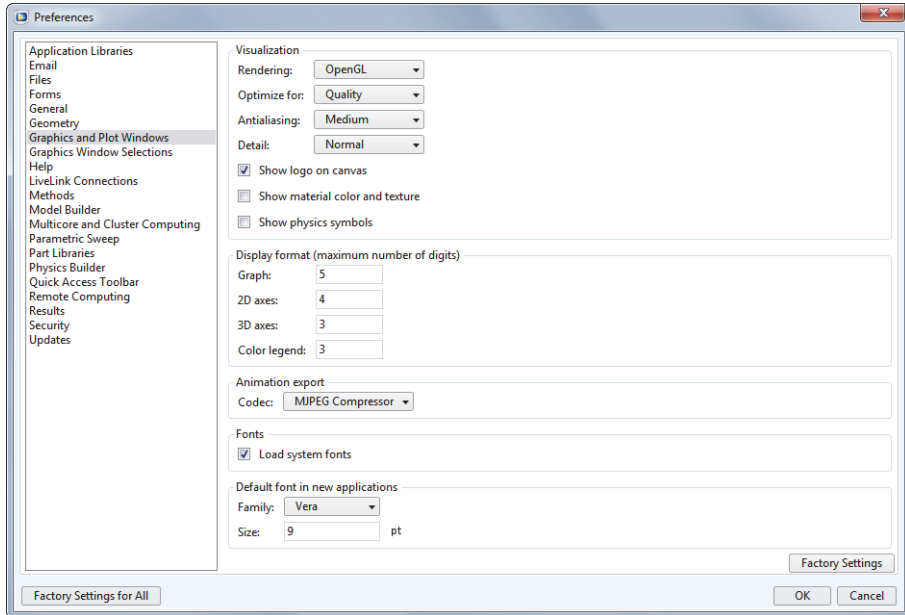

In the Preferences window, you can change settings such as graphics rendering, number of displayed digits for results, maximum number of CPU cores used for computations, or paths to user-defined application libraries. Take a moment to browse your current settings to familiarize yourself with the different options.

There are three graphics rendering options available: OpenGL[®], DirectX[®], and Software Rendering. DirectX[®] is not available in OS X or Linux[®], but is available in Windows[®] if you choose to install the DirectX[®] runtime libraries during installation. If your computer does not have a dedicated graphics card, you may have to switch to Software Rendering for slower but fully functional graphics. A list of recommended graphics cards can be found at:

www.comsol.com/system-requirements

Creating a New Model

You can set up a model guided by the Model Wizard or start from a Blank Model as shown in the figure below.

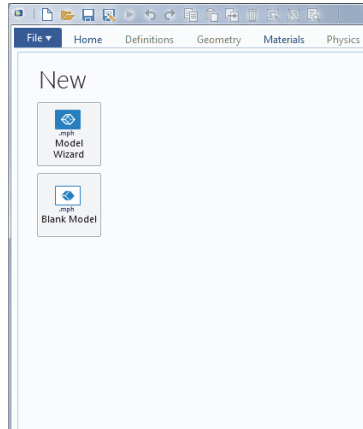

CREATING A MODEL GUIDED BY THE MODEL WIZARD

The Model Wizard will guide you in setting up the space dimension, physics, and study type in a few steps:

- 1 Start by selecting the space dimension for your model component: 3D, 2D Axisymmetric, 2D, 1D Axisymmetric, or 0D.

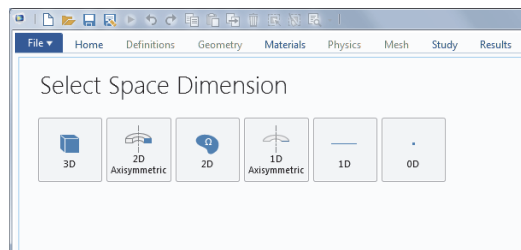

- 2 Now, add one or more physics interfaces. These are organized in a number of Physics branches in order to make them easy to locate. These branches do not directly correspond to products. When products are added to your COMSOL

Multiphysics installation, one or more branches will be populated with additional physics interfaces.

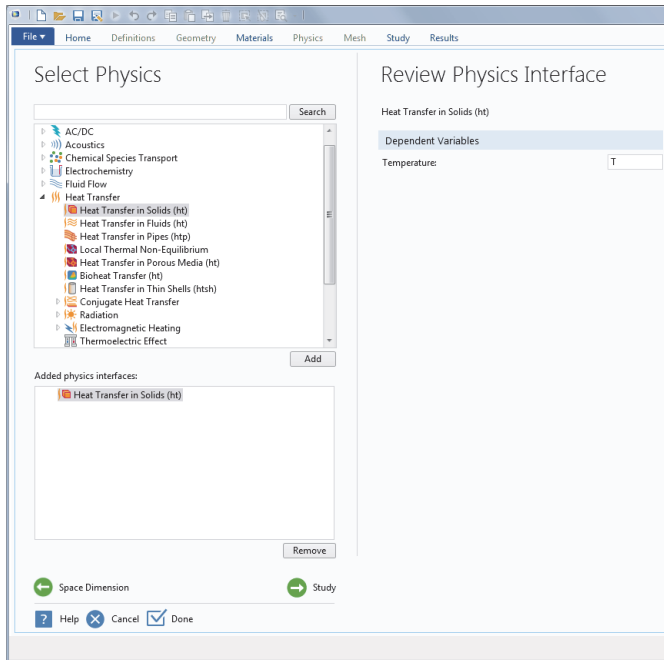

- 3 Select the Study type that represents the solver or set of solvers that will be used for the computation.

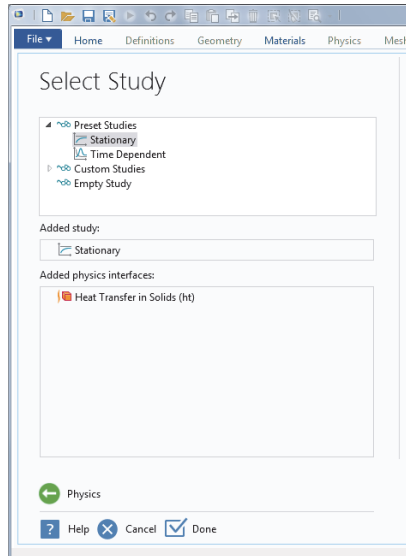

Finally, click Done. The desktop is now displayed with the model tree configured according to the choices you made in the Model Wizard.

CREATING A BLANK MODEL

The Blank Model option will open the COMSOL Desktop interface without any Component or Study. You can right-click the model tree to add a Component of a certain space dimension, a physics interface, or a Study.

The Ribbon and Quick Access Toolbar

The ribbon tabs in the COMSOL Desktop environment reflect the modeling workflow and give an overview of the functionality available for each modeling step, including building simulation applications from your models.

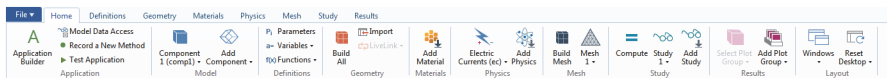

The Home tab contains buttons for the most common operations for making changes to a model, running simulations, and for building and testing applications. Examples include changing model parameters for a parameterized

geometry, reviewing material properties and physics, building the mesh, running a study, and visualizing the simulation results.

There are standard tabs for each of the main steps in the modeling process. These are ordered from left to right according to the workflow: Definitions, Geometry, Materials, Physics, Mesh, Study, and Results.

Contextual tabs are shown only if and when they are needed, such as the 3D Plot Group tab, which is shown when the corresponding plot group is added or when the node is selected in the model tree.

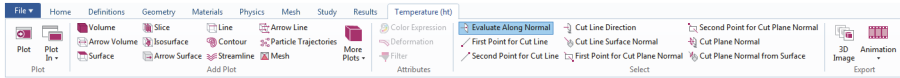

Modal tabs are used for very specific operations, when other operations in the ribbon may become temporarily irrelevant. An example is the Work Plane modal tab. When working with Work Planes, other tabs are not shown since they do not present relevant operations.

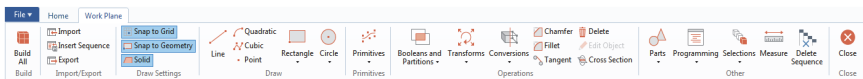

THE RIBBON VS. THE MODEL BUILDER

The ribbon gives quick access to available commands and complements the model tree in the Model Builder window. Most of the functionality accessed from the ribbon is also accessible from contextual menus by right-clicking nodes in the model tree. Certain operations are only available from the ribbon, such as selecting which desktop window to display. In the COMSOL Desktop interface for OS X and Linux[®], this functionality is available from toolbars, which replace the ribbon on these platforms. There are also operations that are only available from the model tree, such as reordering and disabling nodes.

THE QUICK ACCESS TOOLBAR

The Quick Access Toolbar contains a set of commands that are independent of the ribbon tab that is currently displayed. You can customize the Quick Access Toolbar; you can add most commands available in the File menu, commands for undoing and redoing recent actions, for copying, pasting, duplicating, and deleting nodes in the model tree. You can also choose to position the Quick Access Toolbar above or below the ribbon.

OS X AND LINUX[®]

In the COMSOL Desktop environment for OS X and Linux[®], the ribbon is replaced by a set of menus and toolbars:

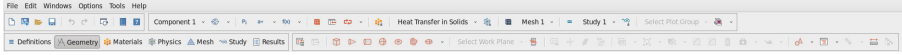

The instructions in this book are based on the Windows[®] version of the COMSOL Desktop environment. However, running COMSOL in OS X and Linux[®] is very similar, keeping in mind that ribbon user interface components can instead be found in the corresponding menus and toolbars.

The Model Builder and the Model Tree

Using the Model Builder, you build a model by starting with the default model tree, adding nodes, and editing the node settings.

All of the nodes in the default model tree are top-level parent nodes. You can right-click on them to see a list of child nodes, or subnodes, that you can add beneath them. This is the means by which nodes are added to the tree.

When you click on a child node, then you will see its node settings in the Settings window. It is here that you can edit node settings.

It is worth noting that if you have the Help window open (which is achieved either by selecting Help from the File menu, or by pressing the function key F1), then you will also get dynamic help (in English only) when you click on a node.

THE ROOT, GLOBAL DEFINITIONS, AND RESULTS NODES

A model tree always has a root node (initially labeled Untitled.mph), a Global Definitions node, and a Results node. The label on the root node is the name of the multiphysics model file, or MPH file, that this model is saved to. The root node has settings for author name, default unit system, and more.

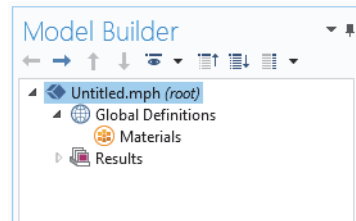

The Global Definitions node has a Materials subnode by default. The Global Definitions node is where you define parameters, variables, functions, and couplings that can be used throughout the model tree. They can be used, for example, to define the values and functional dependencies of material properties, forces, geometry, and other relevant features. The Global Definitions node itself has no settings, but its child nodes have plenty of them. The

Global Definitions>Materials node stores material properties that can be referenced in the Component nodes of a model.

The Results node is where you access the solution after performing a simulation and where you find tools for processing the data. The Results node initially has five subnodes:

- Data Sets, which contain a list of solutions you can work with.
- Derived Values, which defines values to be derived from the solution using a number of postprocessing tools.
- Tables, which is a convenient destination for the Derived Values or for Results generated by probes that monitor the solution in real-time while the simulation is running.
- Export, which defines numerical data, images, and animations to be exported to files.
- Reports, which contains automatically generated or custom reports about the model in HTML or Microsoft® Word® format.

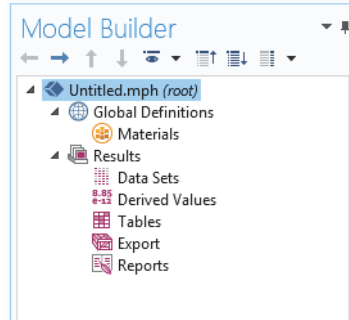

To these five default subnodes, you may also add more Plot Group subnodes that define graphs to be displayed in the Graphics window or in Plot windows. Some of these may be created automatically, depending on the type of simulations you are performing, but you may include additional figures by right-clicking on the Results node and choosing from the list of plot types.

THE COMPONENT AND STUDY NODES

In addition to the three nodes just described, there are two additional top-level node types: Component nodes and Study nodes. These are usually created by the Model Wizard when you create a new model. After using the Model Wizard to specify what type of physics you are modeling and what type of Study (e.g., steady-state, time-dependent,

frequency-domain, or eigenfrequency analysis) you will carry out, the Wizard automatically creates one node of each type and shows you their contents.

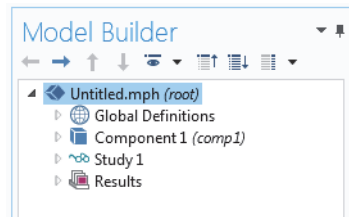

It is also possible to add more Component and Study nodes as you develop the model. A model can contain multiple Component and Study nodes and it would be confusing if they all had the same name. Therefore, these types of nodes can be renamed to be descriptive of their individual purposes.

If a model has multiple Component nodes, they can be coupled to form a more sophisticated sequence of simulation steps.

Note that each Study node may carry out a different type of computation, so each one has a separate Compute button = .

To be more specific, suppose that you build a model that simulates a coil assembly that is made up of two parts, a coil and a coil housing. You can create two Component nodes, one that models the coil and the other the coil housing. You can then rename each of the nodes with the name of the object. Similarly, you can also create two Study nodes, the first simulating the stationary or steady-state behavior of the assembly, and the second simulating the frequency response. You can rename these two nodes to be Stationary and Frequency Domain. When the model is complete, save it to a file named `Coil Assembly.mph`. At that point, the model tree in the Model Builder looks like the figure below.

In this figure, the root node is named `Coil Assembly.mph`, indicating the file in which the model is saved. The Global Definitions node and the Results node each have their default name. Additionally, there are two Component nodes and two Study nodes with the names chosen in the previous paragraph.

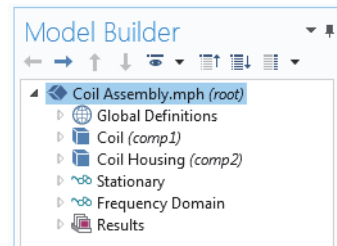
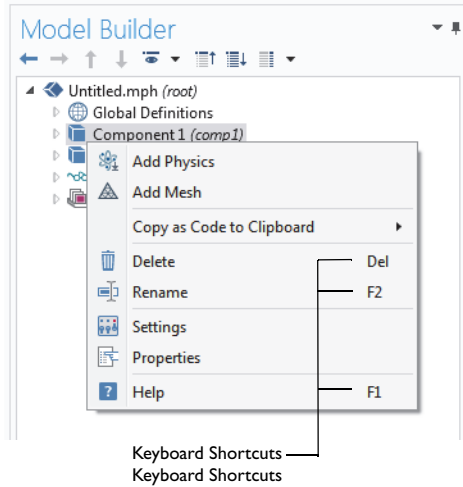

PARAMETERS, VARIABLES, AND SCOPE

Parameters

Parameters are user-defined constant scalars that are usable throughout the model. That is to say, they are “global” in nature. Important uses are:

- Parameterizing geometric dimensions.
- Specifying mesh element sizes.
- Defining parametric sweeps (that is, simulations that are repeated for a variety of different values of a parameter such as a frequency or a load).

A parameter expression can contain numbers, parameters, built-in constants, built-in functions with parameter expressions as arguments, and unary and binary operators. For a list of available operators, see “Appendix C—Language Elements and Reserved Names” on page 155. Because these expressions are evaluated before a simulation begins, parameters may not depend on the time variable t . Likewise, they may not depend on spatial variables like x , y , or z , nor on the dependent variables that your equations are solving for.

It is important to know that the names of parameters are case sensitive.

You define Parameters in the model tree under Global Definitions.

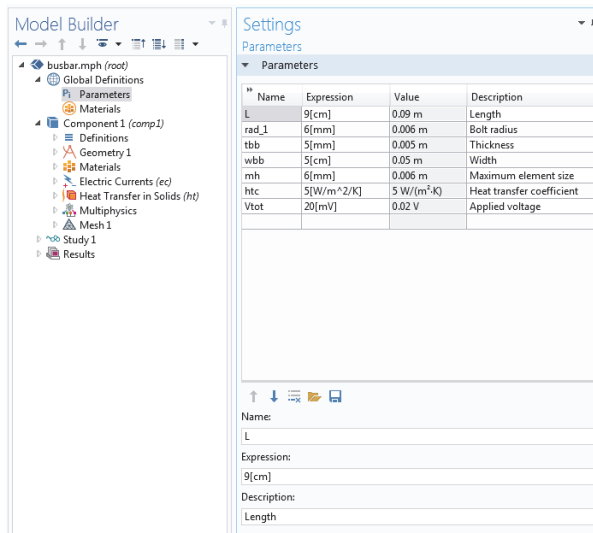

Variables

Variables can be defined either in the Global Definitions node or in the Definitions subnode of any Component node. Naturally, the choice of where to define the

variable depends on whether you want it to be global (that is, usable throughout the model tree) or locally defined within a single Component node. Like a Parameter Expression, a Variable Expression may contain numbers, parameters, built-in constants, and unary and binary operators. However, it may also contain Variables like t , x , y , or z ; functions with Variable Expressions as arguments; and dependent variables that you are solving for in addition to their space and time derivatives.

Variables Used in Applications

Model parameters and variables can be used in applications. For example, you can let the user of an application change the value of a parameter. In addition, variables to be used in applications can be defined in the Application Builder under the Declarations node.

Scope

The “scope” of a Parameter or Variable is a statement about where it may be used in an expression. All Parameters are defined in the Global Definitions node of the model tree. This means that they are global in scope and can be used throughout the model tree.

A Variable may also be defined in the Global Definitions node and have global scope, but they are subject to other limitations. For example, Variables may not be used in Geometry, Mesh, or Study nodes (with the one exception that a Variable may be used in an expression that determines when the simulation should stop).

A Variable that is defined, instead, in the Definitions subnode of a Component node has local scope and is intended for use in that particular Component (but, again, not in Geometry or Mesh nodes). They may be used, for example, to specify material properties in the Materials subnode of a Component or to specify boundary conditions or interactions. It is sometimes valuable to limit the scope of the variable to only a certain part of the geometry, such as certain boundaries. For that purpose, provisions are available in the settings for a Variable to select whether to apply the definition either to the entire geometry of the Component, or only to certain Domains, Boundaries, Edges, or Points.

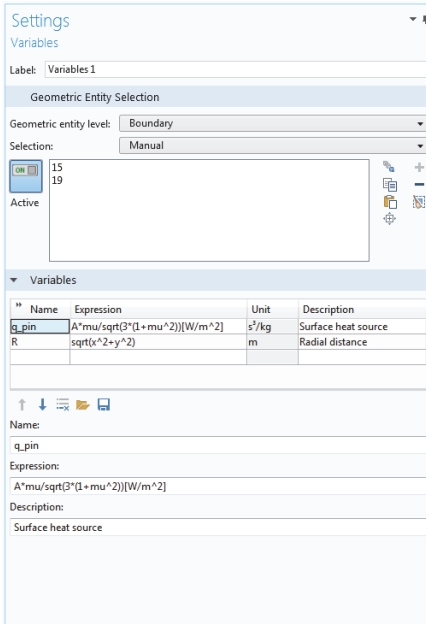

The figure at left shows the definition of two Variables, q_pin and R , for which the scope is limited to just two boundaries identified by numbers 15 and 19.

Such Selections can be named and then referenced elsewhere in a model, such as when defining material properties or boundary conditions that will use the Variable. To give a name to the Selection, click the Create Selection button () to the right of the Selection list.

Although Variables defined in the Definitions subnode of a Component node are intended to have local scope, they can still be accessed outside of the Component node in the model tree by being sufficiently specific about their identity. This is done by using a “dot-notation” where the Variable

name is preceded by the name of the Component node in which it is defined and they are joined by a “dot”. In other words, if a Variable named `foo` is defined in a Component node named `MyModel`, then this variable may be accessed outside of the Component node by using `MyModel.foo`. This can be useful, for example, when you want to use the variable to make plots in the Results node. Variables defined under the Declarations node in the Application Builder are available globally in form objects and methods but cannot be used in the Model Builder.

Built-In Constants, Variables, and Functions

COMSOL Multiphysics comes with many built-in constants, variables, and functions. They have reserved names that cannot be redefined by the user. If you use a reserved name for a user-defined variable, parameter, or function, the text you enter will turn orange (a warning) or red (an error) and you will get a tooltip message if you select the text string.

Some important examples are:

- Mathematical constants such as `pi` (3.14...) or the imaginary unit `i` or `j`

- Physical constants such as `g_const` (acceleration of gravity), `c_const` (speed of light), or `R_const` (universal gas constant)
- The time variable, `t`
- First-and-second-order derivatives of the Dependent variables (the solution) whose names are derived from the spatial coordinate names and Dependent variable names (which are user-defined variables)
- Mathematical functions such as `cos`, `sin`, `exp`, `log`, `log10`, and `sqrt`

See “Appendix C—Language Elements and Reserved Names” on page 155 for more information.

.The following spread shows an example of a customized desktop with additional windows.

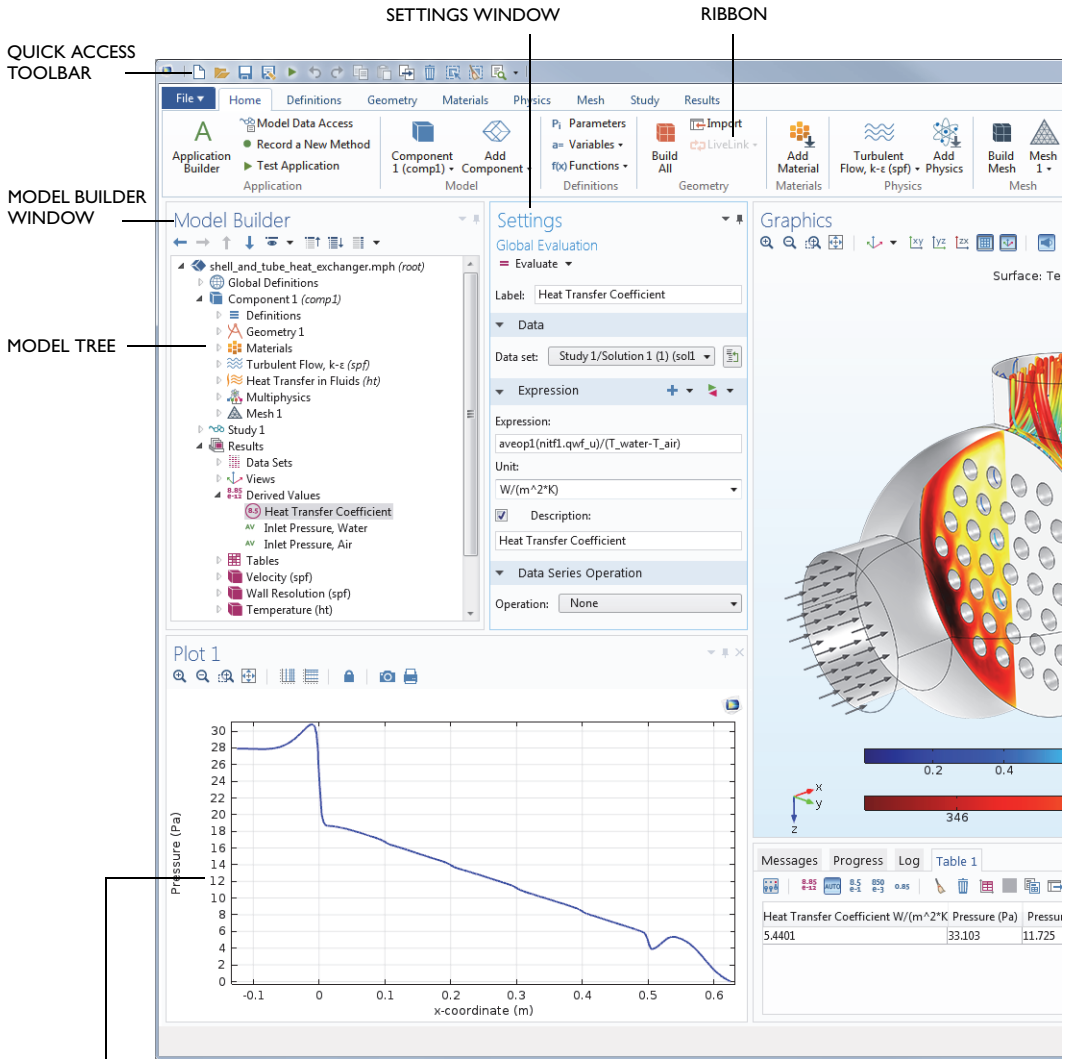

PLOT WINDOW—The Plot window is used to visualize Results quantities, probes, and convergence plots. Several Plot windows can be used to show multiple results simultaneously.

DYNAMIC HELP—Continuously updated with online access to the Knowledge Base and Application Gallery. The Help window enables easy browsing with extended search functionality.

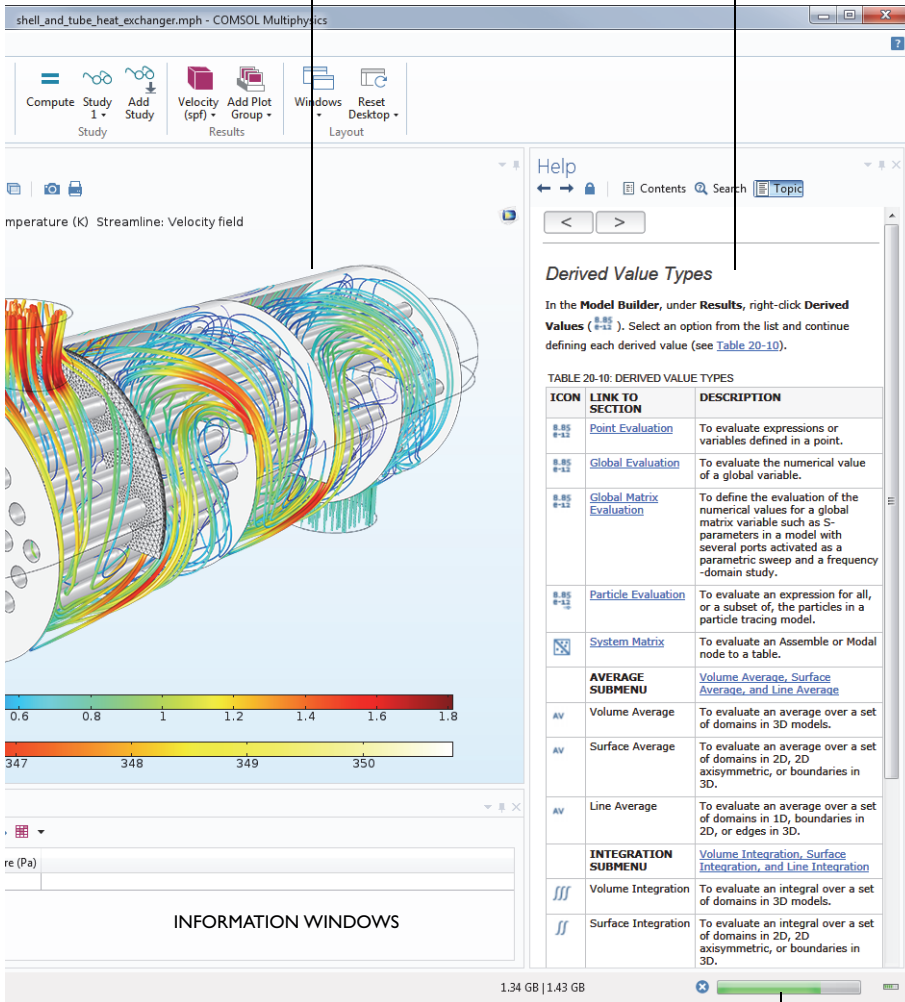

GRAPHICS WINDOW







INFORMATION WINDOWS

PROGRESS BAR WITH CANCEL BUTTON

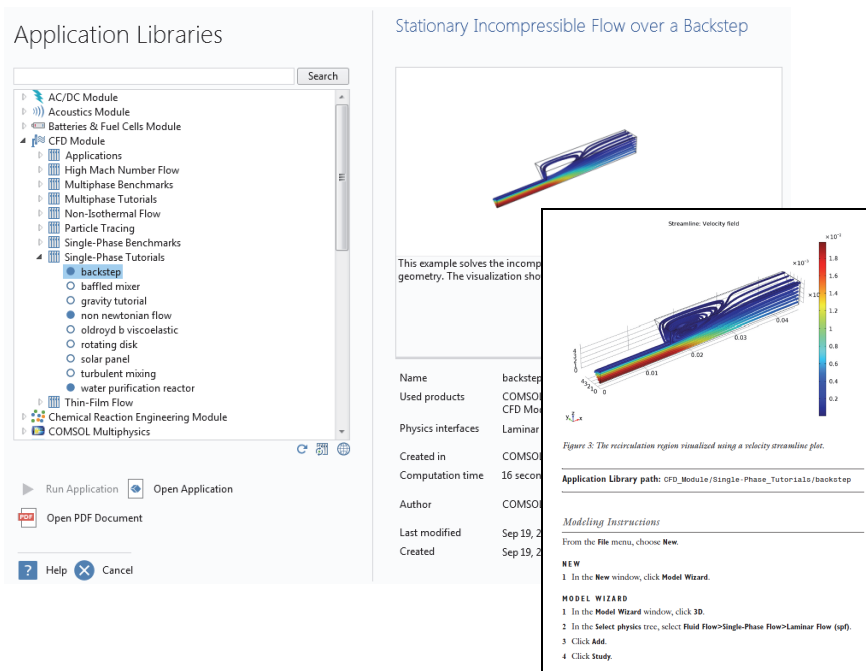

The Application Libraries

The Application Libraries are collections of MPH files containing tutorial models and runnable applications with accompanying documentation. Tutorial models have documentation that includes the theoretical background and step-by-step instructions. Runnable applications have instructions on how to use the application. You can readily edit all tutorial models and applications to make them your own. Each physics-based add-on module comes with its own application library with examples specific to its applications and physics area. You can use the step-by-step instructions and the MPH files as a template for your own modeling. To open the Application Libraries window, on the Home toolbar, Windows menu select Application Libraries  or select File>Application Libraries  and then search by application name or browse under a module folder name.



Click Open Application , Run Application , or Open PDF Document . Alternatively, select File>Help>Documentation in COMSOL Multiphysics to search by application name or browse by module. Note that the Run Application option is only available for MPH files that are runnable applications.

The MPH files in the COMSOL Application Library can have two formats—Full MPH files or Compact MPH files:

- Full MPH files, including all meshes and solutions. In the Application Libraries window, these appear with the  icon. If the MPH file's size exceeds 25MB, a tip with the text “Large file” and the file size appears when you position the cursor at the model's node in the Application Libraries tree.
- Compact MPH files with all settings for the model but without built meshes and solution data to save space on the DVD (a few MPH files have no solutions for other reasons). You can open these to study the settings and to mesh and re-solve the applications. It is also possible to download the full versions—with meshes and solutions—of most of these when you update your Application Library. These appear in the Application Libraries window with the  icon. If you position the cursor at a compact file in the Application Libraries window, a “No solutions stored” message appears. If a full MPH file is available for download, the corresponding node's context menu includes a Download File with Solutions  option.

The Application Libraries are updated on a regular basis by COMSOL. To check all available updates, select Update COMSOL Application Library  from the File>Help menu (Windows[®] users) or from the Help menu (OS X and Linux[®] users). This connects you to the COMSOL website where you can access new applications and the latest updates.

Workflow and Sequence of Operations

In the Model Builder window, every step of the modeling process, from defining global variables to the final report of results, is displayed in the model tree.

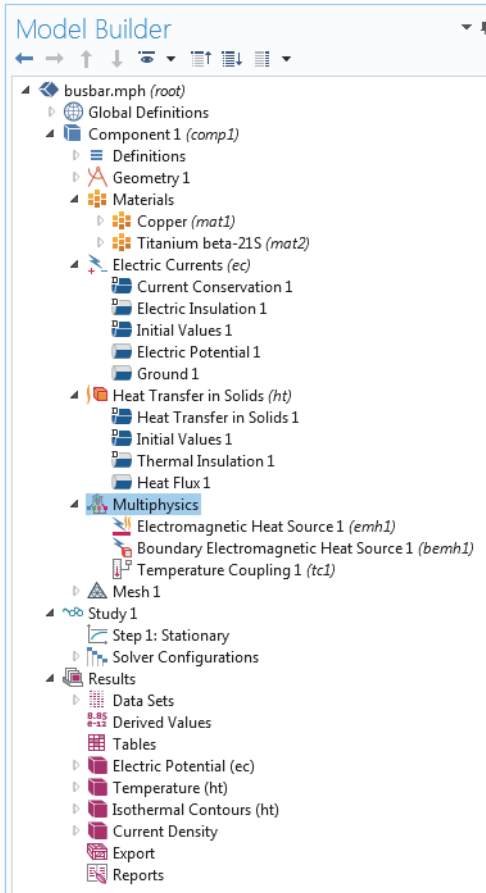

From top to bottom, the model tree defines an orderly sequence of operations.

In the following branches of the model tree, the node order makes a difference and you can change the sequence of operations by moving the subnodes up or down the model tree:

- Geometry
- Materials
- Physics

- Mesh
- Study
- Plot Groups

In the Component Definitions branch of the tree, the ordering of the following node types also makes a difference:

- Perfectly Matched Layer
- Infinite Elements

Nodes may be reordered by these methods:

- Drag-and-drop
- Right-clicking the node and selecting Move Up or Move Down
- Pressing Ctrl + up-arrow or Ctrl + down-arrow

In other branches, the ordering of nodes is not significant with respect to the sequence of operations, but some nodes can be reordered for readability. Child nodes to Global Definitions is one such example.

You can view the sequence of operations presented as program code statements by saving the model as a model file for MATLAB[®] or as a model file for Java[®] after having selected Compact History in the File menu. Note that the model history keeps a complete record of the changes you make to a model as you build it. As such, it includes all of your corrections including changes to parameters and boundary conditions and modifications of solver methods. Compacting this history removes all of the overridden changes and leaves a clean copy of the most recent form of the model steps. You can also use the Record a New Method option to view and edit program code statements in the Method editor of the Application Builder.

As you work with the COMSOL Desktop interface and the Model Builder, you will grow to appreciate the organized and streamlined approach. But any description of a user interface is inadequate until you try it for yourself. So, in the next chapters, you are invited to work through two examples to familiarize yourself with the software.

Example 1: Structural Analysis of a Wrench

This simple example requires none of the add-on products to COMSOL Multiphysics®. For more fully-featured structural mechanics models, see the Structural Mechanics Module application library.

At some point in your life, it is likely that you have tightened a bolt using a wrench. This exercise takes you through a structural mechanics model that analyzes this basic task from the perspective of the structural integrity of the wrench subjected to a worst-case loading.

The wrench is, of course, made from steel, a ductile material. If the applied torque is too high, the tool will be permanently deformed due to the steel's elastoplastic behavior when pushed beyond its yield stress level. To analyze whether the wrench handle is appropriately dimensioned, you will check if the mechanical stress level is within the yield stress limit.

This tutorial gives a quick introduction to the COMSOL workflow. It starts with opening the Model Wizard and adding a physics option for solid mechanics. Then a geometry is imported and steel is selected as the material. You then explore the other key steps in creating a model by defining a parameter and boundary condition for the load, selecting geometric entities in the Graphics window, defining the Mesh and Study, and finally examining the results numerically and through visualization.

If you prefer to practice with a more advanced model, read this section to familiarize yourself with some of the key features, and then go to the tutorial “Example 2: The Busbar—A Multiphysics Model” on page 53.

Model Wizard

- 1 To start the software, double-click the COMSOL icon on the desktop, which will take you to the New window with two options for creating a new model: Model Wizard or Blank Model.

If you select Blank Model, you can right-click the root node in the model tree to manually add a Component and a Study. For this tutorial, click the Model Wizard button.

If COMSOL is already open, you can start the Model Wizard by selecting New from the File menu. Choose the Model Wizard.

The Model Wizard will guide you through the first steps of setting up a model. The next window lets you select the dimension of the modeling space.

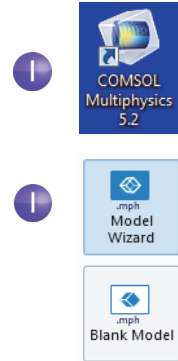

- 2 In the Select Space Dimension window, select 3D.

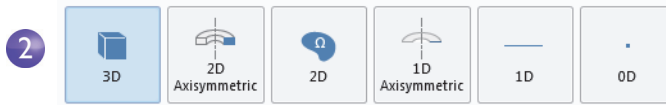



- 3 In Select Physics, select Structural Mechanics > Solid Mechanics (solid). Click Add.

Without add-on modules, Solid Mechanics is the only physics interface available in the Structural Mechanics folder. In the picture to the right, the Structural Mechanics folder is shown as it appears when all add-on modules are available.

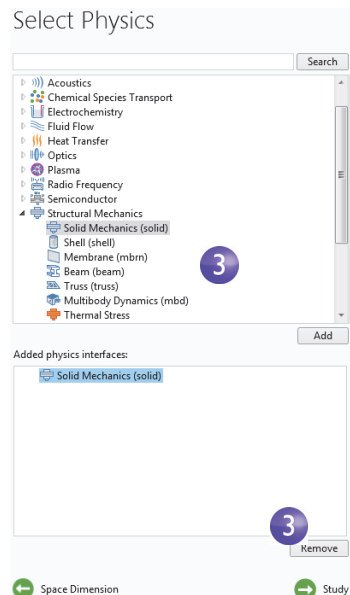
Click Study → to continue.



- 4 Click **Stationary**  under **Preset Studies**. Click **Done**  once you have finished.

Preset Studies have solver and equation settings adapted to the selected physics; in this example, Solid Mechanics. A Stationary study is used in this case—there are no time-varying loads or material properties.

Any selection from the Custom Studies branch  requires manual settings.

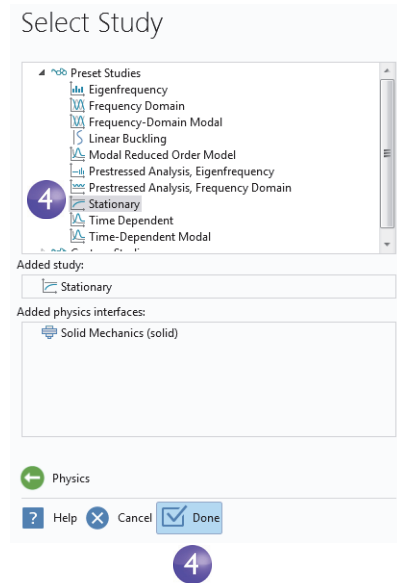

Geometry

This tutorial uses a geometry that was previously created and stored in the COMSOL native CAD format, `.mphbin`. To learn how to build your own geometry, see “Appendix A—Building a Geometry” on page 136.

File Locations

The location of the application library that contains the file used in this exercise varies based on the software installation and operating system. In Windows[®], the file path will be similar to:

`C:\Program Files\COMSOL\COMSOL52\Multiphysics\applications.`

- 1 In the Model Builder window, under Component 1, right-click Geometry 1 and select Import .

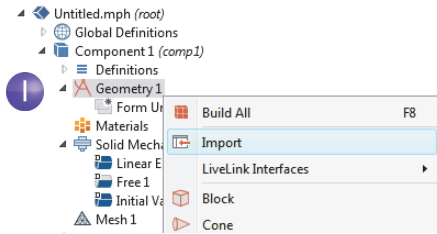

As an alternative, you can use the ribbon and click Import  from the Geometry tab.



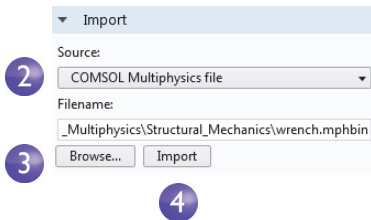

- 2 In the Settings window for Import, from the Geometry import list, select COMSOL Multiphysics file.

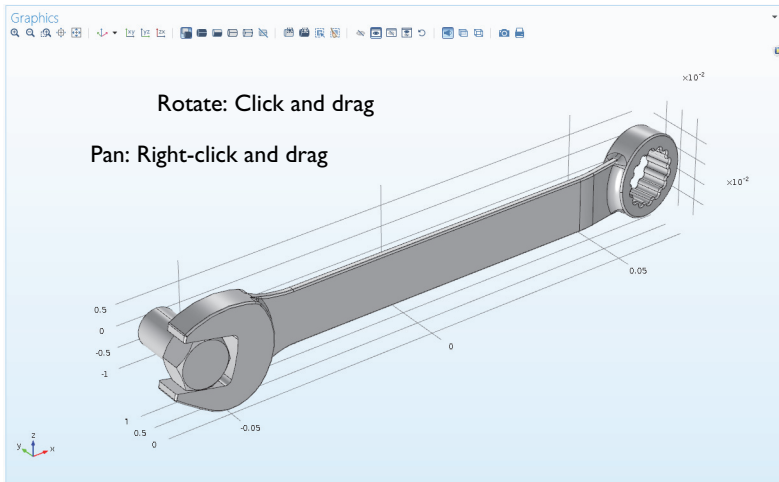

- 3 Click Browse and locate the file wrench.mphbin in the application library folder of the COMSOL installation folder. Its default location in Windows[®] is
C:\Program
Files\COMSOL\COMSOL52\Multiphysics\applications\COMSOL_Multiphysics\
Structural_Mechanics\wrench.mphbin
Double-click to add or click Open.

4 Click Import to display the geometry in the Graphics window.



5 Click the wrench geometry in the Graphics window and then experiment with moving it around. As you point to or click the geometry, it changes color. Click the Zoom In , Zoom Out , Go to Default 3D View , Zoom Extents , and Transparency  buttons on the Graphics window toolbar to see what happens to the geometry:

- To rotate, click and drag anywhere in the Graphics window.
- To move, right-click and drag.
- To zoom in and out, click the mouse scroll wheel, continue holding it, and drag.
- To get back to the original position, click the Go to Default 3D View  button on the toolbar.

Also see “Appendix B—Keyboard and Mouse Shortcuts” on page 151 for additional information.



The imported model has two parts, or domains, corresponding to the bolt and the wrench. In this exercise, the focus will be on analyzing the stress in the wrench.

Materials

The Materials node  stores the material properties for all physics and all domains in a Component node. Use the same generic steel material for both the bolt and tool. Here is how to choose it in COMSOL.

1 Open the Add Materials window.

You can open the Add Materials window in either of these two ways:

- Right-click Component 1 > Materials  in the Model Builder and select Add Material 
- From the ribbon, select the Home tab and then click Add Material.

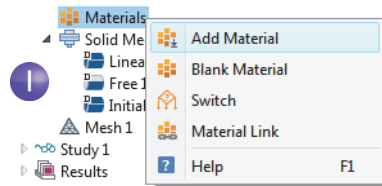

2 In the Add Material window, click to expand the Built-In directory. Scroll down to find Structural steel, right-click, and select Add to Component 1.

3 Examine the Material Contents section in the Settings window for Material to see the properties that are available. Properties with green check marks are used by the physics in the simulation.

4 Close the Add Material window.

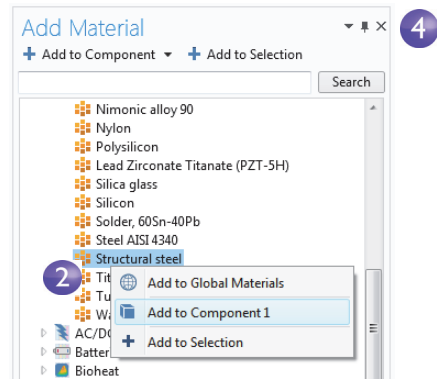

3



Material Contents					
Property	Name	Value	Unit	Property group	
<input checked="" type="checkbox"/>	Density	rho	7850[kg/m^3]	kg/m ³	Basic
<input checked="" type="checkbox"/>	Young's modulus	E	200e9[Pa]	Pa	Young's modulus and Poisson's ratio
<input checked="" type="checkbox"/>	Poisson's ratio	nu	0.33	1	Young's modulus and Poisson's ratio
<input type="checkbox"/>	Relative permeability	mur	1	1	Basic
<input type="checkbox"/>	Heat capacity at constant pressure	Cp	475[J/(kg*K)]	J/(kg-K)	Basic
<input type="checkbox"/>	Thermal conductivity	k	44.5[W/(m*K)]	W/(m-K)	Basic
<input type="checkbox"/>	Electrical conductivity	sigma	4.032e6[S/m]	S/m	Basic
<input type="checkbox"/>	Relative permittivity	epsilon_r	1	1	Basic
<input type="checkbox"/>	Coefficient of thermal expansion	alpha	12.3e-6[1/K]	1/K	Basic
<input type="checkbox"/>	Murnaghan third-order elastic moduli	l	-3.0e11[Pa]	N/m ²	Murnaghan
<input type="checkbox"/>	Murnaghan third-order elastic moduli	m	-6.2e11[Pa]	N/m ²	Murnaghan
<input type="checkbox"/>	Murnaghan third-order elastic moduli	n	-7.2e11[Pa]	N/m ²	Murnaghan

 Also see the busbar tutorial sections “Materials” on page 61 and “Customizing Materials” on page 98 to learn more about working with materials.

Global Definitions

You will now define a global parameter specifying the load applied to the wrench.

Parameters

- 1 In the Model Builder, right-click Global Definitions  and choose Parameters .
- 2 Go to the Settings window for Parameters. Under Parameters in the Parameters table or in the fields below the table, enter these settings:
 - In the Name column or field, enter F.
 - In the Expression column or field, enter 150[N]. The square-bracket notation is used to associate a physical unit to a numerical value, in this case the unit of force in Newtons. The Value column is automatically updated based on the expression entered once you leave the field or press Return.
 - In the Description column or field, enter Applied force.

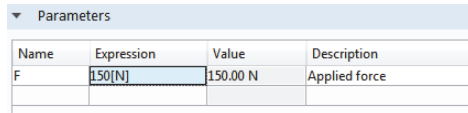

Name	Expression	Value	Description
F	150[N]	150.00 N	Applied force



If you have a Parameters table with more than one entry, you can sort the table with respect to a particular column by clicking on the corresponding header.

The sections “Global Definitions” on page 57 and “Parameters, Functions, Variables and Couplings” on page 94 show you more about working with parameters.

So far you have added the physics and study, imported a geometry, added the material, and defined one parameter. The Model Builder node sequence should now match the figure to the right. The default feature nodes under Solid Mechanics are indicated by a ‘D’ in the upper-left corner of the node icon.

The default nodes for Solid Mechanics are: a Linear Elastic Material model, Free boundary conditions that allow all boundaries to move freely without a constraint or load, and Initial Values for specifying initial displacement and velocity values for a nonlinear or transient analysis (not applicable in this case).

At any time, you can save your model and then open it later in exactly the state in which it was saved.

- 3 From the File Menu, select File > Save As. Browse to a folder where you have write permissions, and save the file as `wrench.mph`.

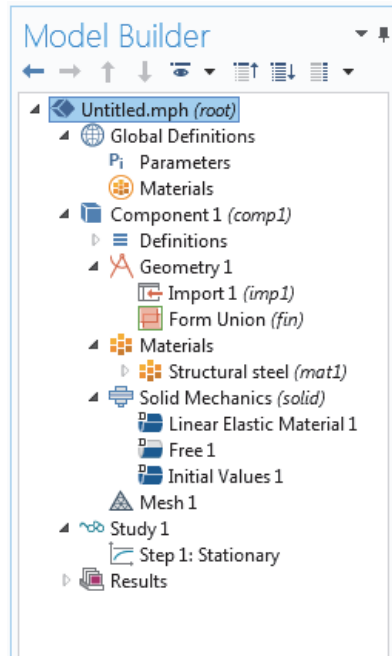

Domain Physics and Boundary Conditions

With the geometry and materials defined, you are now ready to set the boundary conditions.

- 1 In the Model Builder, right-click Solid Mechanics (solid) and select Fixed Constraint.

This boundary condition constrains the displacement of each point on a boundary surface to be zero in all directions.

You can also use the ribbon and select, from the Physics tab, Boundaries > Fixed Constraint.

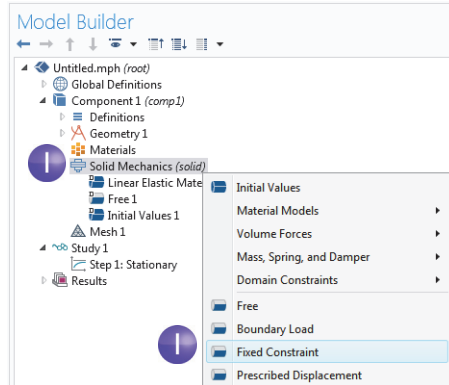

- 2 In the Graphics window, rotate the geometry by clicking anywhere in the window and then dragging the wrench into the position shown. Click on the exposed front surface of the partially modeled bolt. The boundary turns blue indicating that it has been selected. The Boundary number in the Selection list should be 35.

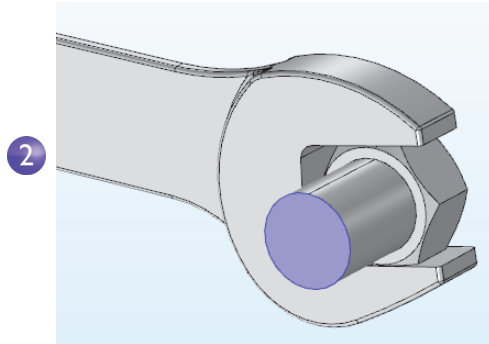

- 3 Click the Go to Default 3D View button on the Graphics toolbar to restore the geometry to the default view.



- In the Model Builder, right-click Solid Mechanics (solid) and select Boundary Load. A Boundary Load node is added to the Model Builder sequence.

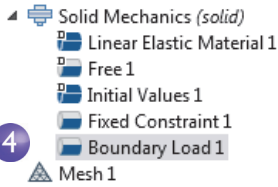

- In the Graphics window, click the Zoom Box button on the toolbar and drag the mouse to select the square region shown in the figure to the right. Release the mouse button to zoom in on the selected region.

5

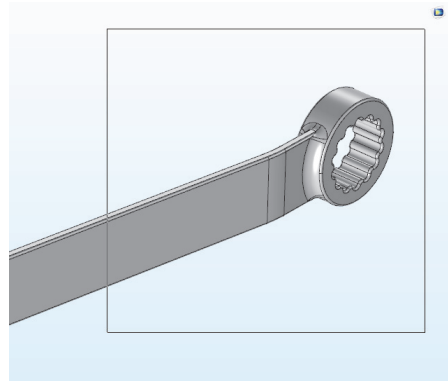

- Select the top socket face (Boundary 111) by clicking the boundary to highlight it in blue and add it to the Selection list.

6

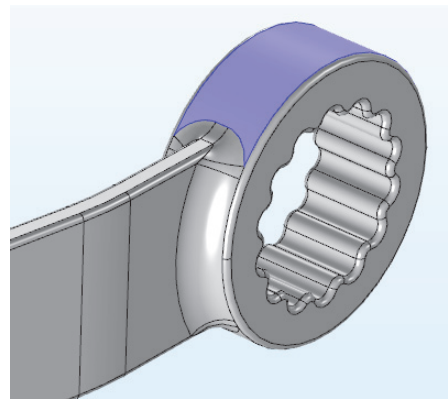

7 In the Settings window for Boundary Load, under Force, select Total force as the Load type and enter $-F$ in the text field for the z component. The negative sign indicates the negative z direction (downward). With these settings, the load of 150 N will be distributed uniformly across the selected surface.

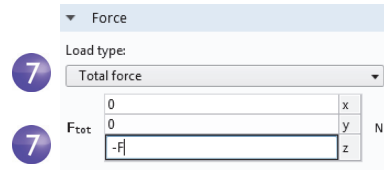

Note that to simplify the modeling process, the mechanical contact between the bolt and the wrench is approximated with a material interface boundary condition. Such an internal boundary condition is automatically defined by COMSOL and guarantees continuity in normal stress and displacement across a material interface. A more detailed analysis including mechanical contact can be done with the Structural Mechanics Module.

Mesh

The mesh settings determine the resolution of the finite element mesh used to discretize the model. The finite element method divides the model into small elements of geometrically simple shapes, in this case tetrahedrons. In each tetrahedron, a set of polynomial functions is used to approximate the structural displacement field—how much the object deforms in each of the three coordinate directions.

In this example, because the geometry contains small edges and faces, you will define a slightly finer mesh than the default setting suggests. This will better resolve the variations of the stress field and give a more accurate result. Refining the mesh size to improve computational accuracy always involves some sacrifice in speed and typically requires increased memory usage.

1 In the Model Builder, under Component 1 click Mesh 1 . In the Settings window for Mesh, under Mesh Settings, select Fine from the Element size list.

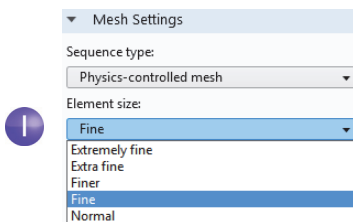

2 Click the Build All button in the Settings window or on the Mesh toolbar.

- 3 After a few seconds the mesh is displayed in the Graphics window. Rotate the wrench to take a look at the element size distribution.

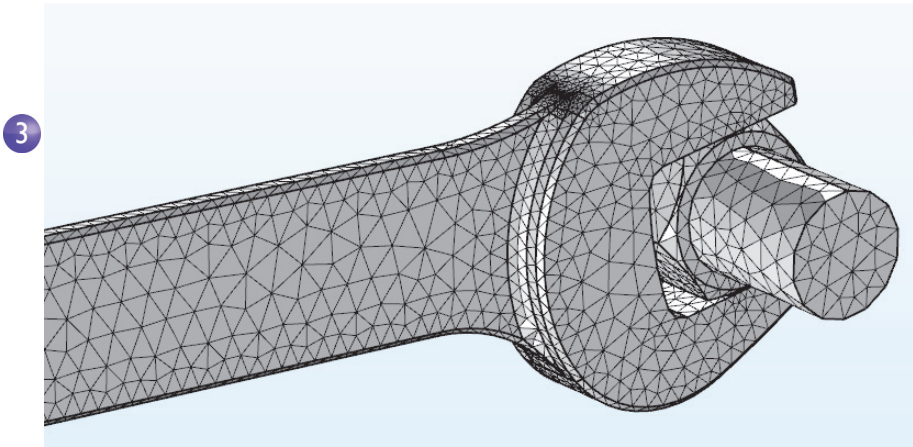

Study



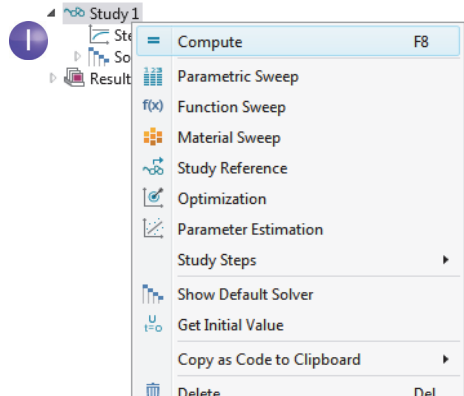

In the beginning of setting up the model you selected a Stationary study, which implies that COMSOL will use a stationary solver. For this to be applicable, the assumption is that the load, deformation, and stress do not vary in time. The default solver settings will be good for this simulation if your computer has more than 2 GB of in-core memory (RAM). If you should run out of memory, the instructions below show solver settings that make the solver run a bit slower but use up less memory. To start the solver:

- 1 Right-click Study 1  and select Compute = (or press F8).



 If your computer's memory is below 2 GB you may at this point get an error message “Out of Memory During LU Factorization”. LU factorization is one of the numerical methods used by COMSOL for solving the large sparse matrix equation system generated by the finite element method.

You can easily solve this example model on a memory-limited machine by allowing the solver to use the hard drive instead of performing all of the computation using RAM. The steps below show how to do this. If your computer has more than 2 GB of RAM you can skip to the end of this section (after step 5 below).

- 1 If you did not already start the computation, you can access the solver settings from the Study node. In the Model Builder, right-click Study 1  and choose Show Default Solver .
- 2 Under Study 1>Solver Configurations, expand the Solution 1  node.
- 3 Expand the Stationary Solver 1  node and click Direct .

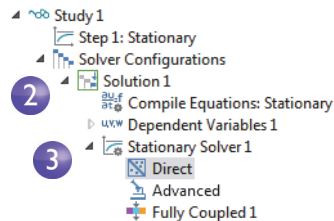

A Direct solver is a fast and very robust type of solver that requires little or no manual tuning in order to solve a wide range of physics problems. The drawback is that it may require large amounts of RAM.

- 4 In the Settings window for Direct, in the General section, select the Out-of-core check box. Change the In-core memory method to Manual. Leave the default In-core memory (MB) setting of 512 MB.

This setting ensures that if your computer runs low on RAM during computation, the solver will start using the hard drive as a complement to RAM. Allowing the solver to use the hard drive instead of just RAM will slow the computation down somewhat.

- 5 Right-click Study 1  and select Compute = (or press F8).

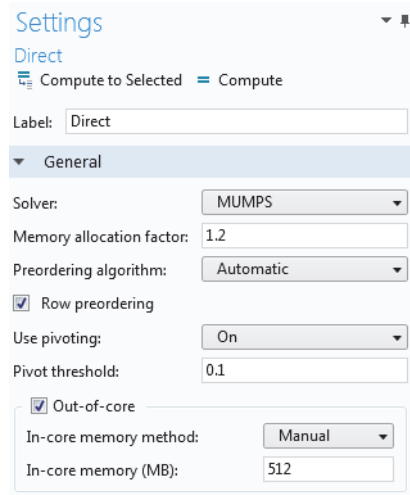

After a few seconds of computation time, the default plot is displayed in the Graphics window. You can find other useful information about the computation in the Messages and Log windows; click the Messages and Log tabs under the Graphics window to see the kind of information available to you. The Messages window can also be opened from the Windows drop-down list in the Home tab of the ribbon.

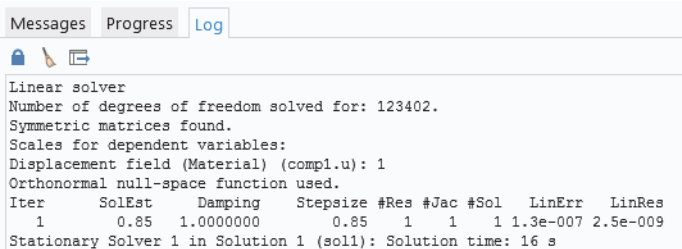

Displaying Results

The von Mises stress is displayed in the Graphics window in a default Surface plot with the displacement visualized using a Deformation subnode. Change the default unit (N/m^2) to the more suitable MPa as shown in the following steps.

- 1 In the Model Builder, expand the Results>Stress (solid) node, then click Surface 1.

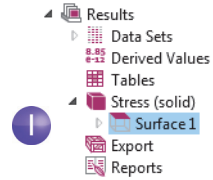

- 2 In the Settings window under Expression, from the Unit list select MPa (or type MPa in the field).

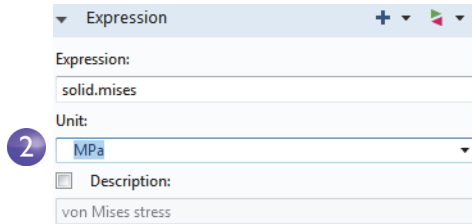

- 3 To study the stress more accurately, expand the Quality section. From the Recover list select Within domains. This setting will recover information about the stress level from a collection of elements rather than from each element individually. It is not active by default since it makes visualizations slower. The Within domain setting treats each domain separately, and the stress recovery will not cross material interfaces.

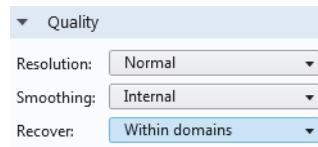

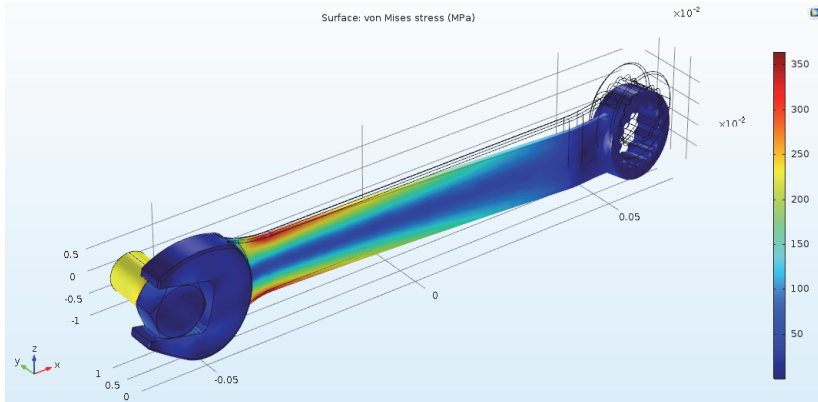

- 3 Click the Plot button  on the toolbar of the Settings window for the Surface plot and then click the Go to Default 3D View button  on the Graphics window toolbar.

The plot is regenerated with the updated unit and using the Within domain recovery setting. The von Mises stress distribution is shown in the bolt and wrench under an applied vertical load.



For a typical steel used for tools like a wrench, the yield stress is about 600 MPa, which means that we are getting close to plastic deformation for our 150 N load (which corresponds to about 34 pounds force). You may also be interested in a safety margin of, say, a factor of three. To quickly assess which parts of the wrench are at risk of plastic deformation, you can plot an inequality expression such as `solid.mises>200[MPa]`.

- 1 Right-click the Results node  and add a 3D Plot Group .

2 Right-click the 3D Plot Group 2 node  and select Surface .

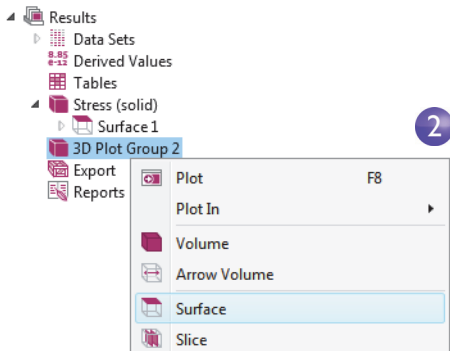

3 In the Settings window for Surface, click the Replace Expression button  and select Model>Component1>Solid Mechanics>Stress>solid.mises-von Mises stress by double-clicking. When you know the variable name beforehand, you can also directly enter `solid.mises` in the Expression field. Now edit this expression to: `solid.mises>200[MPa]`.

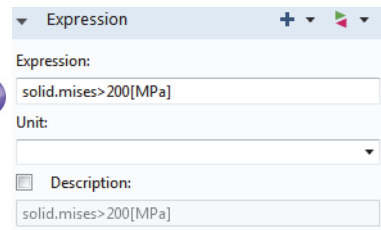

This is a boolean expression that evaluates to either 1, for true, or 0, for false. In areas where the expression evaluates to 1, the safety margin is exceeded. Here, you also use the Recover feature described earlier.

4 Click the Plot button .

5 In the Model Builder, click 3D Plot Group 2. Press F2 and in the Rename 3D Plot Group dialog box, enter `Safety Margin`. Click OK.

The resulting plot shows that the stress in the bolt is high, but the focus of this exercise is on the wrench. If you wished to comfortably certify the wrench for a

150 N load with a factor-of-three safety margin, you would need to change the handle design somewhat, such as making it wider.

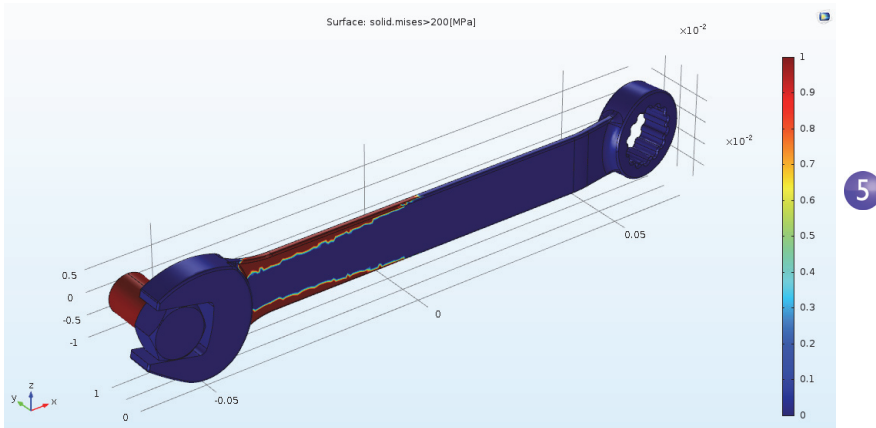

You may have noticed that the manufacturer, for various reasons, has chosen an asymmetric design for the wrench. Because of that, the stress field may be different if the wrench is flipped around. Try now, on your own, to apply the same force in the other direction and visualize the maximum von Mises stress to see if there is any difference.

Convergence Analysis

To check the accuracy of the computed maximum von Mises stress in the wrench, you can now continue with a mesh convergence analysis. Do that by using a finer mesh and therefore a higher number of degrees of freedom (DOFs).

! This section illustrates some more in-depth functionality and the steps below could be skipped at a first reading. In order to run the convergence analysis below, a computer with at least 4GB of memory (RAM) is recommended.

EVALUATING THE MAXIMUM VON MISES STRESS

- I To study the maximum von Mises stress in the wrench, in the Results section of the model tree, right-click the Derived Values $\frac{0.05}{0.05}$ node and select Maximum>Volume Maximum $\frac{0.05}{0.05}$ **MAX**.

- 2 In the Settings window for Volume Maximum, under Selection, choose Manual and select the wrench, domain 1, by clicking on the wrench in the Graphics window. We will only consider values in the wrench domain and neglect those in the bolt.
- 3 In the Expression text field enter the function `ppr(solid.mises)`. The function `ppr()` corresponds to the Recover setting in the earlier note on page 44 for Surface plots. The Recover setting with the `ppr` function is used to increase the quality of the stress field results. It uses a polynomial-preserving recovery (`ppr`) algorithm, which is a higher-order interpolation of the solution on a patch of mesh elements around each mesh vertex. It is not active by default since it makes Results evaluations slower.
- 4 Under Expression, select or enter MPa as the Unit.

- 5 In the Settings window for Volume Maximum, click Evaluate to evaluate the maximum stress. The result will be displayed in a Table window and will be approximately 364 MPa.

ppr(solid.mises) (MPa)	
363.91	

- 6 To see where the maximum value is attained, you can use a Max/Min Volume plot. Right-click the Results node and add a 3D Plot Group.
- 7 Right-click the 3D Plot Group 3 node and select More Plots>Max/Min Volume.
- 8 In the Settings window for Max/Min Volume, in the Expression text field, enter the function `ppr(solid.mises)`.
- 9 In the Settings window under Expression, from the Unit list select MPa (or enter MPa in the field).

- Click the Plot button . This type of plot simultaneously shows the location of the max and min values and also their coordinate location in the table below.

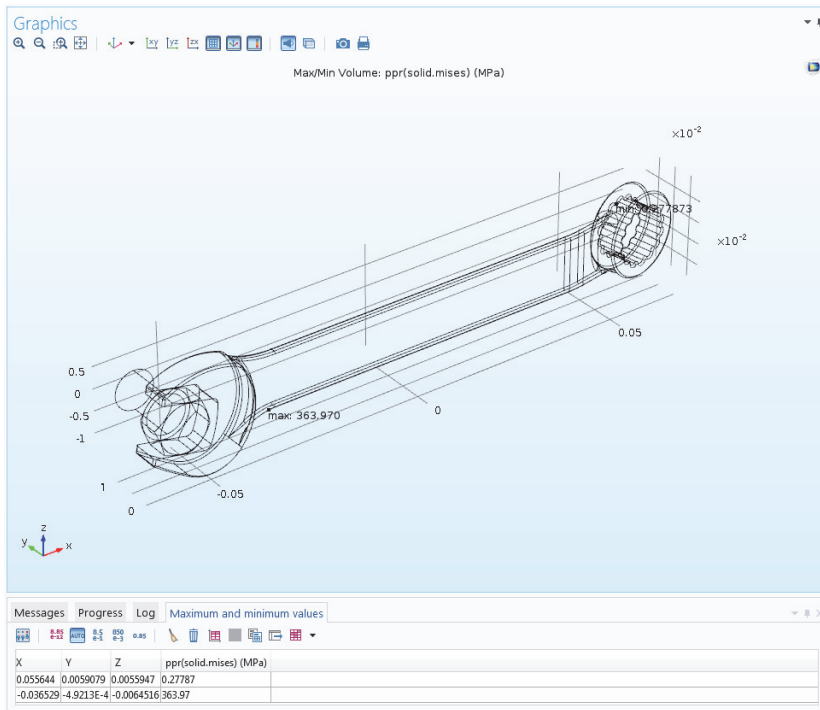

PARAMETERIZING THE MESH

We will now define a parametric sweep for successively refining the mesh size while solving and then finally plot the maximum von Mises stress vs. mesh size. First, let's define the parameters that will be used for controlling the mesh density.

- In the Model Builder, click Parameters P_1 under Global Definitions .
- Go to the Settings window for Parameters. In the Parameters table (or under the table in the fields), enter these settings:
 - In the Name column or field, enter `hd`. This parameter will be used in the parametric sweep to control the element size.
 - In the Expression column or field, enter `1`.
 - In the Description column or field, enter `Element size divider`.

3 Now, enter another parameter with Name h_0 , Expression 0.01 , and Description Starting element size. This parameter will be used to define the element size at the start of the parametric sweep.

Name	Expression	Value	Description
F	150[N]	150.00 N	Applied force
hd	1	1.0000	Element size divider
h_0	0.01	0.010000	Starting element size

4 In the Model Builder, under Component 1, click Mesh 1 . In the Settings window for Mesh select User-controlled mesh from the Sequence type list.

5 Under Mesh 1, click the Size node .

6 In the Settings window for Size, under Element Size, click the Custom button.

Under Element Size Parameters, enter:

- h_0/h_d in the Maximum element size field.
- $h_0/(4 * h_d)$ in the Minimum element size field.
- 1.3 in the Maximum element growth rate field.
- 0.1 in the Curvature factor field.
- 0.2 in the Resolution of narrow regions field.

Element Size Parameters

Maximum element size: m

Minimum element size: m

Maximum element growth rate:

Curvature factor:

Resolution of narrow regions:

See page 71 for more information on the Element Size Parameters.

PARAMETRIC SWEEP AND SOLVER SETTINGS

As a next step, add a parametric sweep for the parameter h_d .

1 In the Model Builder, right-click Study 1 and select Parametric Sweep . A Parametric Sweep node is added to the Model Builder sequence.

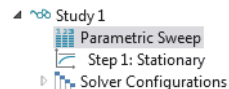

2 In the Settings window for Parametric Sweep, under the table in the Study Settings section, click the Add button . From the Parameter names list in the table, select h_d .



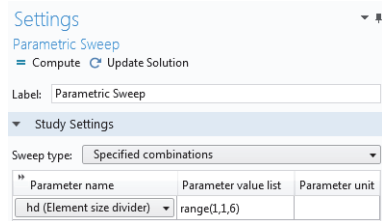

- 3 Enter a range of Parameter values to sweep for. Click the Range  button and enter the values in the Range dialog box. In the Start field, enter 1. In the Step field, enter 1, and in the Stop field, enter 6. Click Replace. The Parameter value list will now display range(1,1,6).



The settings above make sure that as the sweep progresses, the value of the parameter *hd* increases and the maximum and minimum element sizes decrease.

See page 123 for more information on defining parametric sweeps.

For the highest value of *hd*, the number of DOFs will exceed one million. Therefore, we will switch to a more memory-efficient iterative solver.

- 4 Under Study 1>Solver Configurations>Solution 1, expand the Stationary Solver 1 node, right-click Stationary Solver 1 , and select Iterative . The Iterative solver option typically reduces memory usage but can require physics-specific tailoring of the solver settings for efficient computations.
- 5 Under General in the Settings window for Iterative, set Preconditioning to Right. (This is a low-level solver option, which in this case will suppress a warning message that would otherwise appear. However, this setting does not affect the resulting solution. Preconditioning is a mathematical transformation used to prepare the finite element equation system for using the Iterative solver.)
- 6 Right-click the Iterative 1 node  and select Multigrid . The Multigrid iterative solver uses a hierarchy of meshes of different densities and different finite element shape function orders.
- 7 Click the Study 1 node and select Compute =, either in the Settings window or by right-clicking the node. You can also click Compute in the ribbon Home or Study tab. The computation time will be a few minutes (depending on the computer hardware) and memory usage will be about 4GB.

RESULTS ANALYSIS

As a final step, analyze the results from the parametric sweep by displaying the maximum von Mises stress in a Table.

- 1 In the Model Builder under Results>Derived values, select the Volume Maximum 1 node .

The solutions from the parametric sweep are stored in a new Data Set named Study 1/Parametric Solutions 1. Now change the Volume Maximum settings accordingly:

2 In the Settings window for Volume Maximum, change the Data set to Study 1/Parametric Solutions 1.

3 Click the arrow next to the Evaluate button at the top of the Settings window for Volume Maximum and select to evaluate in a New Table. This evaluation may take a minute or so.

hd	ppr(solid.mises) (MPa)
1.0000	357.88
2.0000	364.78
3.0000	368.97
4.0000	369.64
5.0000	369.43
6.0000	369.64

4 To plot the results in the Table, click the Table Graph  button at the top of the Table window.

It is more interesting to plot the maximum value vs. the number of DOFs. This is possible by using a built-in variable `numberofDOFs`.

5 Right-click the Derived Values node  and select Global Evaluation .

6 In the Settings window for Global Evaluation, change the Data set to Study 1/Parametric Solutions 1.

7 In the Expressions field, enter `numberofDOFs`.

8 Click the arrow next to the Evaluate button in the Settings window for Global Evaluation and select to evaluate in Table 2. This displays the DOF values for each parameter next to the previously evaluated data.

This convergence analysis shows that the computed value of the maximum von Mises stress in the wrench handle will increase from the original 355 MPa, for a mesh with about 60,000 DOFs, to 370 MPa for a mesh with about 1,100,000 DOFs. It also shows that 300,000 DOFs essentially gives the same accuracy as 1,100,000 DOFs; see the table below.

DEGREES OF FREEDOM	COMPUTED MAX VON MISES STRESS (MPA)
58,899	354.8
177,918	364.3
314,181	368.5
585,849	369.0
862,509	369.6
1,126,380	369.8

This concludes the wrench tutorial.

Example 2: The Busbar—A Multiphysics Model

Electrical Heating in a Busbar

This tutorial demonstrates the concept of multiphysics modeling in COMSOL. We will do this by defining the different physics settings sequentially. At the end, you will have built a truly multiphysics model.

The model that you are about to create analyzes a busbar designed to conduct direct current to an electrical device (see picture below). The current conducted in the busbar, from bolt 1 to bolts 2a and 2b, produces heat due to the resistive losses, a phenomenon referred to as Joule heating. The busbar is made of copper while the bolts are made of a titanium alloy. Under normal operational conditions the currents are predominantly conducted through the copper. This example, however, illustrates the effects of an unwanted electrical loading of the busbar through the bolts. The choice of materials is important because titanium has a lower electrical conductivity than copper and will be subjected to a higher current density.

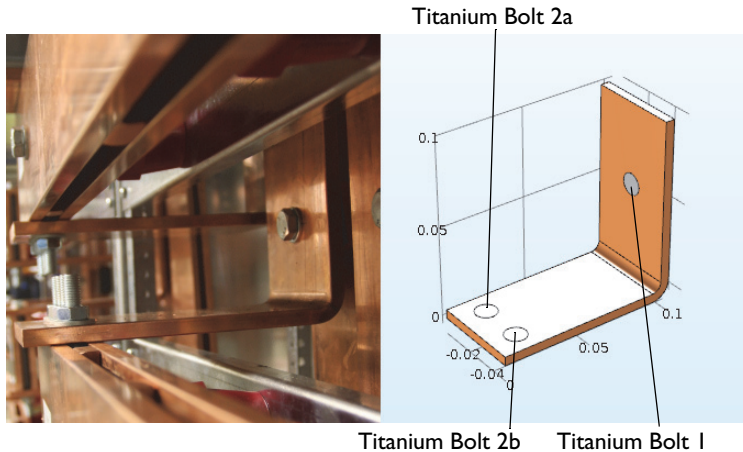

The goal of your simulation is to precisely calculate how much the busbar heats up. Once you have captured the basic multiphysics phenomena, you will have the chance to investigate thermal expansion yielding structural stresses and strains in the busbar and the effects of cooling by an air stream.

The Joule heating effect is described by conservation laws for electric current and energy. Once solved for, the two conservation laws give the temperature and electric field, respectively. All surfaces, except the bolt contact surfaces, are cooled by natural convection in the air surrounding the busbar. You can assume that the exposed parts of the bolt do not contribute to the cooling or heating of the device.

The electric potential at the upper-right vertical bolt surface is 20 mV and the potential at the two horizontal surfaces of the lower bolts is 0 V. This corresponds to a relatively high and potentially unsafe loading of this type of busbar. More advanced boundary conditions for electromagnetics analysis are available with the AC/DC Module, such as the capability to give the total current on a boundary.

Busbar Model Overview

More in-depth and advanced topics included in this tutorial are used to show you some of the many options available in COMSOL. The following topics are covered:

- “Parameters, Functions, Variables and Couplings” on page 94, where you learn how to define functions and component couplings.
- “Material Properties and Material Libraries” on page 98 shows you how to customize a material and add it to your own material library.
- “Adding Meshes” on page 100 gives you the opportunity to add and define two different meshes and compare them in the Graphics window.
- “Adding Physics” on page 102 explores the multiphysics capabilities by adding Solid Mechanics and Laminar Flow to the busbar model.
- “Parametric Sweeps” on page 123 shows you how to vary the width of the busbar using a parameter and then solve for a range of parameter values. The result is a plot of the average temperature as a function of the width.
- In the section “Parallel Computing” on page 132 you learn how to solve the model using Cluster Computing.

Model Wizard

- I To open the software, double-click the COMSOL icon on the desktop.

When the software opens, click the Model Wizard button. You can also start the Model Wizard at any time by selecting New from the File menu. Then, choose Model Wizard.

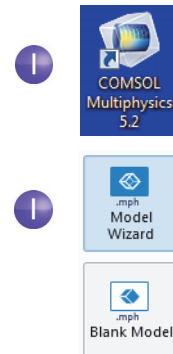

2 In the Select Space Dimension window, click 3D.

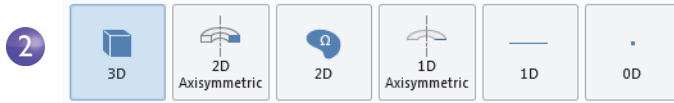



3 In the Select Physics window, expand the Heat Transfer > Electromagnetic Heating folder, then right-click Joule Heating and choose Add Physics. Click the Study button.

You can also double-click or click the Add button to add physics.

Another way to add physics is to open the Add Physics window by right-clicking the Component node in the Model Builder and selecting Add Physics.

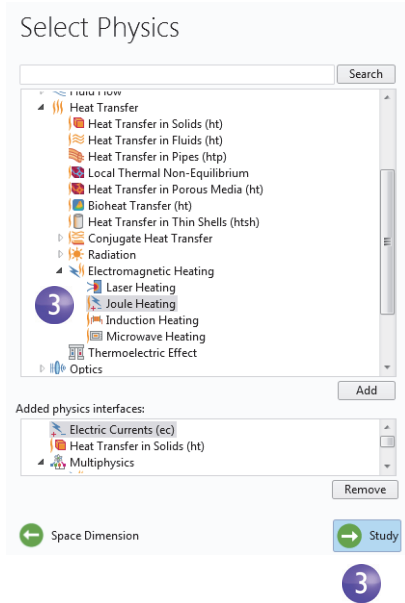
Note, you may have fewer items in your physics list depending on the add-on modules installed. The figure on the right is shown for the case where all add-on modules are installed.



4 In the Select Study window, click to select the Stationary  study type.

Click the Done button.

Preset Studies are studies that have solver and equation settings adapted to the selected physics; in this example, Joule Heating.

Any selection from the Custom Studies branch  needs manual fine-tuning.

Note, you may have fewer study types in your study list depending on the installed add-on modules.

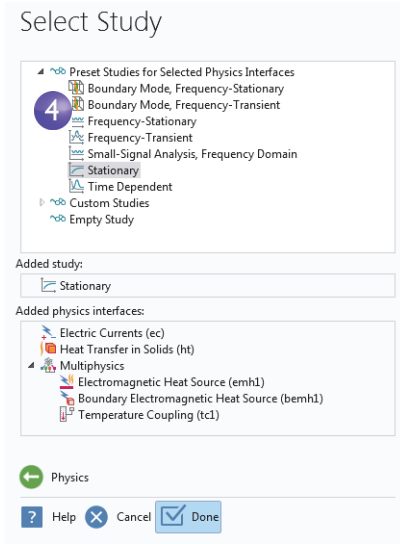

4

 The Joule Heating multiphysics interface consists of two physics interfaces, Electric Currents and Heat Transfer in Solids, together with the multiphysics couplings that appear in the Multiphysics branch: the electromagnetic heat sources and a temperature coupling. This multiphysics approach is very flexible and makes it possible to fully use the capabilities of the participating physics interfaces.

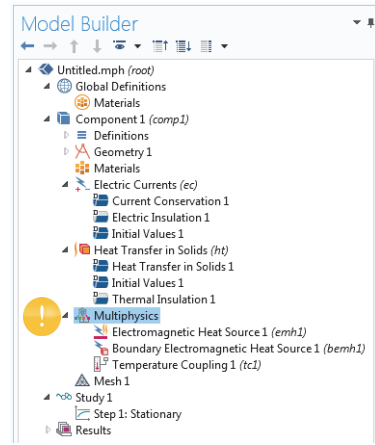

Global Definitions

To save time, it's recommended that you load the geometry from a file. In that case, you can skip to “Geometry” on page 58.

If, on the other hand, you want to draw the geometry yourself, the Global Definitions node is where you define the parameters. First, complete steps 1 through 3 below to define the parameter list for the model. Then follow step 4 and skip to the section “Appendix A—Building a Geometry” on page 136.

The Global Definitions node  in the Model Builder stores Parameters, Variables, and Functions with a global scope. The model tree can hold several model components simultaneously, and the definitions with a global scope are made available for all components. In this particular example, there is only one Component node in which the parameters are used, so if you wish to limit the scope to this single component you could define, for example, Variables and Functions in the Definitions subnode available directly under the corresponding Component node. However, no Parameters can be defined here because Parameters are always global.

Since you will run a parametric study of the geometry later in this example, define the geometry using parameters from the start. In this step, enter parameters for the length of the lower part of the busbar, L , the radius of the titanium bolts, rad_1 , the thickness of the busbar, tbb , and the width of the device, wbb .

You will also add the parameters that control the mesh, mh , a heat transfer coefficient for cooling by natural convection, htc , and a value for the voltage across the busbar, Vtot .

- 1 Right-click Global Definitions  and choose Parameters P_1 . In the Parameters table, click the first row under Name and enter L .
- 2 Click the first row under Expression and enter the value of L , $9[\text{cm}]$. You can enter the unit inside the square brackets.
- 3 Continue adding the other parameters: rad_1 , tbb , wbb , mh , htc , and Vtot according to the Parameters list below. It is a good idea to enter descriptions for

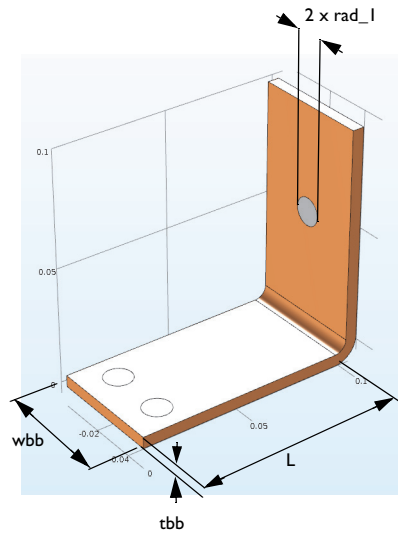

variables in case you want to share the model with others and for your own future reference.

Parameters			
Name	Expression	Value	Description
L	9[cm]	0.09 m	Length
rad_1	6[mm]	0.006 m	Bolt radius
tbb	5[mm]	0.005 m	Thickness
wbb	5[cm]	0.05 m	Width
mh	6[mm]	0.006 m	Maximum element size
htc	5[W/m^2/K]	5 W/(m^2·K)	Heat transfer coefficient
Vtot	20[mV]	0.02 V	Applied voltage

- Click the Save button  on the Quick Access Toolbar and name the model busbar .mph. Then go to “Appendix A—Building a Geometry” on page 136.

Geometry

This section describes how the geometry can be opened from the Application Libraries. The physics, study, parameters, and geometry are included with the model file you are about to open.

- Select Application Libraries  from the Windows drop down in the Home tab.

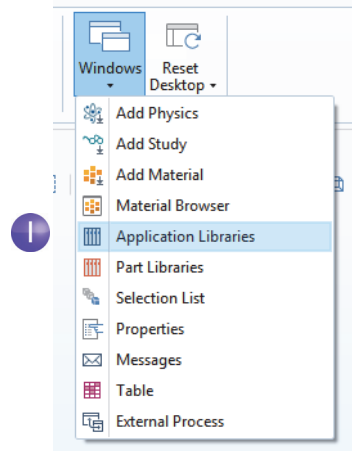



- In the Application Libraries tree under COMSOL Multiphysics > Multiphysics, select busbar geom.

To open the file you can:



- Double-click the name
- Right-click and select an option from the menu
- Click one of the buttons under the tree

You can select No if prompted to save untitled.mph.

The geometry in this file is parameterized. In the next few steps, we will experiment with different values for the width parameter, *wbb*.

- Under Global Definitions  click the Parameters node .

In the Settings window for Parameters, click in the Expression column for the *wbb* parameter and enter 10[cm] to change the value of the busbar width.

- In the Model Builder, under Component 1>Geometry 1, click the Form Union node  and then the Build All button in the Settings window  to rerun the geometry sequence. You can

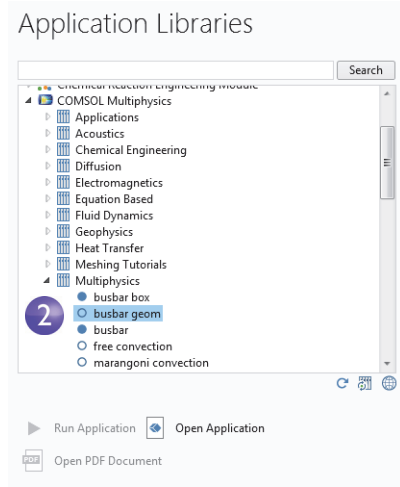

3

Parameters		
Name	Expression	Value
L	9[cm]	0.09 m
rad_1	6[mm]	0.006 m
tbb	5[mm]	0.005 m
wbb	10[cm]	0.1 m
mh	6[mm]	0.006 m
htc	5[W/m^2/K]	5 W/(m^2.K)
Vtot	20[mV]	0.02 V

also use the ribbon and click Build All from the Geometry group in the Home tab.

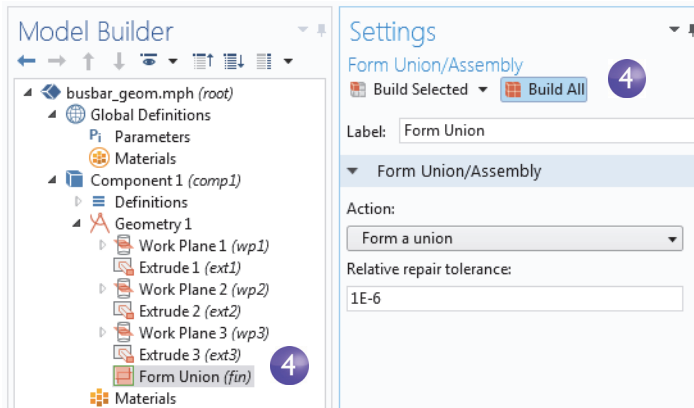

- 5 In the Graphics toolbar click the Zoom Extents button  to see the wider busbar in the Graphics window.

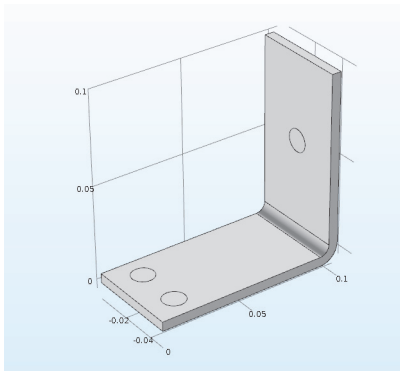
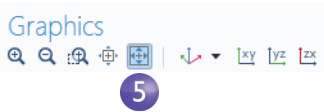

wbb=5cm

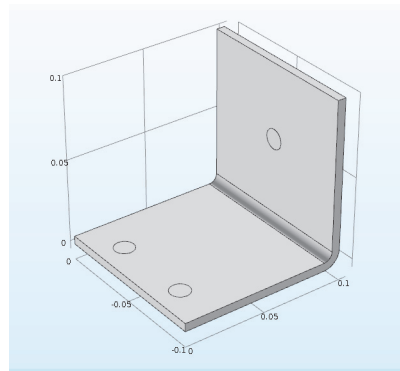



wbb=10cm

6 Experiment with the geometry in the Graphics window:

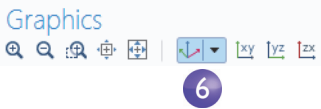
- To rotate the busbar, click and drag the pointer anywhere in the Graphics window.
- To move it, right-click and drag.
- To zoom in and out, click the scroll wheel, continue holding it, and drag.
- To get back to the original position, click the Go to Default 3D View button  on the toolbar.



7 Return to the Parameters table and change the value of `wbb` back to 5 [cm].

8 In the Model Builder, click the Form Union node  and then click the Build All button  to rerun the geometry sequence.

9 On the Graphics toolbar, click the Zoom Extents button .

10 If you built the geometry yourself, you are already using the `busbar.mph` file, but if you opened the file from the Application Libraries, select Save As from the File menu and rename the model `busbar.mph`.

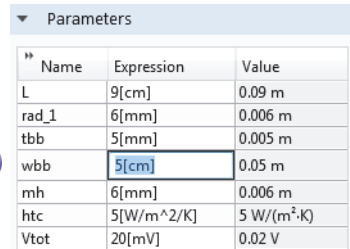



Name	Expression	Value
L	9[cm]	0.09 m
rad_1	6[mm]	0.006 m
tbb	5[mm]	0.005 m
wbb	5[cm]	0.05 m
mh	6[mm]	0.006 m
htc	5[W/m^2/K]	5 W/(m^2.K)
Vtot	20[mV]	0.02 V

After creating or importing the geometry, it is time to define the materials.

Materials



The Materials node  stores the material properties for all physics and geometrical domains in a Component node. The busbar is made of copper and the bolts are made of a titanium alloy. Both of these materials are available from the Built-In material database.

1 In the Model Builder, right-click Component 1>Materials  and select Add Material . By default, the window will open at the right-hand side of the desktop. You can move the window by clicking on the window title and then

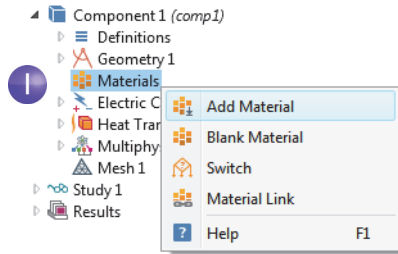
dragging it to a new location. While dragging the window, you will be presented with several options for docking.



 The Materials node will show a red \times in the lower-left corner if you try to solve without first defining a material (you are about to define that in the next few steps).

- 2 In the Add Material window, expand the Built-In materials folder and locate Copper. Right-click Copper  and select Add to Component 1. A Copper node is added to the Model Builder.
- 3 In the Add Material window, scroll to Titanium beta-21S in the Built-In material folder list. Right-click and select Add to Component 1.
- 4 In the Model Builder, collapse the Geometry 1 node  to get an overview of the model.

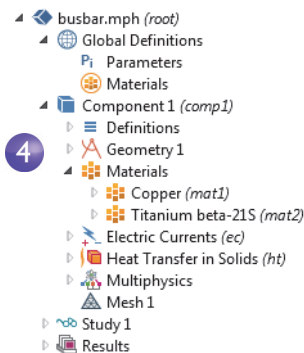
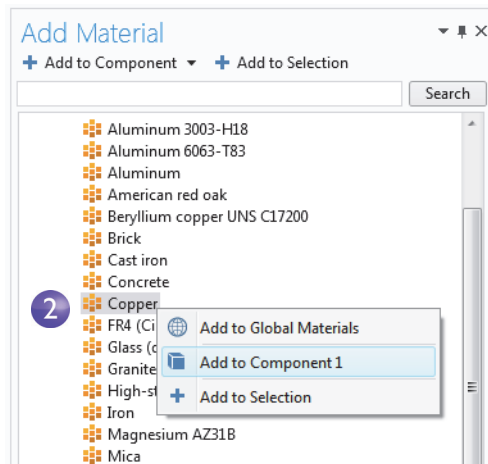

5 Under the Materials node, click Copper  .

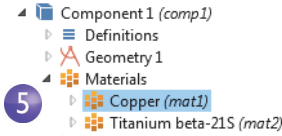

6 In the Settings window for Material, examine the Material Contents section.

6

Property	Name	Value	Unit	Property group
<input checked="" type="checkbox"/> Electrical conductivity	sigma	5.998e7[S/m]	S/m	Basic
<input checked="" type="checkbox"/> Heat capacity at constant pressure	Cp	385[J/(kg*K)]	J/(kg-K)	Basic
<input checked="" type="checkbox"/> Relative permittivity	epsilon _r	1	1	Basic
<input checked="" type="checkbox"/> Density	rho	8960[kg/m ³]	kg/m ³	Basic
<input checked="" type="checkbox"/> Thermal conductivity	k	400[W/(m*K)]	W/(m-K)	Basic
Relative permeability	mu _r	1	1	Basic
Coefficient of thermal expansion	alpha	17e-6[1/K]	1/K	Basic
Young's modulus	E	110e9[Pa]	Pa	Young's modulus and Poisson's ratio
Poisson's ratio	nu	0.35	1	Young's modulus and Poisson's ratio
Reference resistivity	rho ₀	1.72e-8[ohm...]	Ω-m	Linearized resistivity
Resistivity temperature coefficient	alpha	0.0039[1/K]	1/K	Linearized resistivity
Reference temperature	Tref	298[K]	K	Linearized resistivity

The Material Contents section has useful information about the material property usage of a model. Properties that are both required by the physics and available from the material are marked with a green check mark . Properties required by the physics but missing in the material are marked with a warning sign . A property that is available but not used in the model is unmarked.

 The Coefficient of thermal expansion in the table above is not used, but will be needed later when heat-induced stresses and strains are added to the model.

Because the copper material is added first, by default all parts have copper material assigned. In the next step you will assign titanium properties to the bolts, which overrides the copper material assignment for those parts.

7 In the Model Builder, click Titanium beta-21S  .

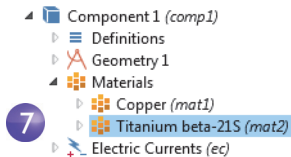

- 8 Select All Domains from the Selection list and then click domain 1 in the list. Now remove domain 1 from the selection list.

To remove a domain from the selection list (or any geometric entity such as boundaries, edges, or points), you can use either of these two methods:

- Click domain 1 in the selection list found in the Settings window for Material, then click the Remove from Selection button  or press **Delete** on your keyboard.
- Alternatively, in the Graphics window, click domain 1 to remove it from the selection list.

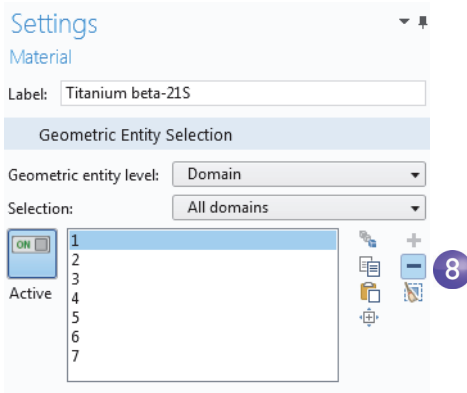

- 8 The domains 2, 3, 4, 5, 6, and 7 are highlighted in blue.

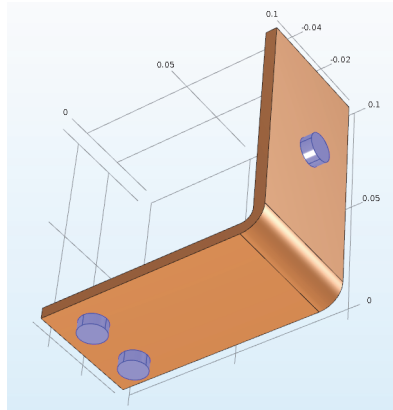
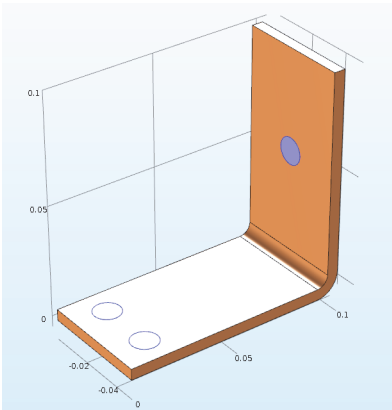

! To render the copper components in the actual color of the material, open the Preferences window from the File menu. Then on the Graphics and Plot Windows page, select the Show material color and texture check box. This will also enable material-true rendering of the other materials.

9 In the Settings window for Material, be sure to inspect the Material Contents section for the titanium material. All the properties used by the physics should have a green check mark .

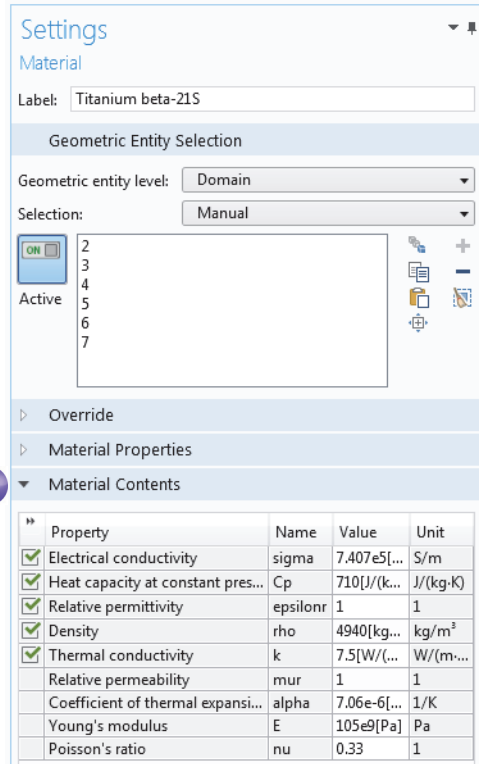

The screenshot shows the 'Settings' window for a material named 'Titanium beta-215'. The 'Material Contents' section is expanded, showing a table of properties. A purple circle with the number '9' is overlaid on the left side of the table.

Property	Name	Value	Unit
<input checked="" type="checkbox"/> Electrical conductivity	sigma	7.407e5[...	S/m
<input checked="" type="checkbox"/> Heat capacity at constant pres...	Cp	710[J/(k...]	J/(kg·K)
<input checked="" type="checkbox"/> Relative permittivity	epsilon	1	1
<input checked="" type="checkbox"/> Density	rho	4940[kg...]	kg/m ³
<input checked="" type="checkbox"/> Thermal conductivity	k	7.5[W/(...]	W/(m·...]
Relative permeability	mu	1	1
Coefficient of thermal expansi...	alpha	7.06e-6[...]	1/K
Young's modulus	E	105e9[Pa]	Pa
Poisson's ratio	nu	0.33	1

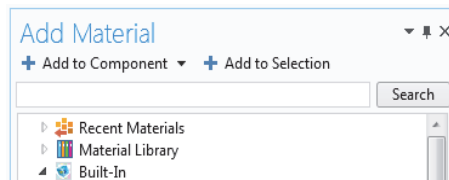

10 Close the Add Material window either by clicking the icon in the upper right corner or by clicking the Add Material toggle button  in the Materials group of the ribbon Home tab.



The screenshot shows the 'Add Material' window. It has a search bar and a list of material categories: Recent Materials, Material Library, and Built-In. A purple circle with the number '10' is overlaid on the right side of the window.

Physics

Next you will inspect the physics domain settings and set the boundary conditions for the heat transfer problem and the conduction of electric current.

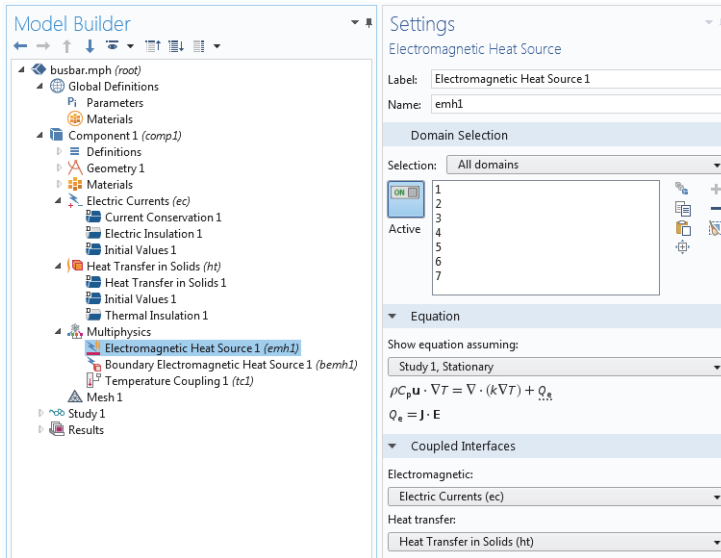

In the Model Builder window, examine the default physics nodes of the multiphysics interface for Joule Heating. First, collapse the Materials node. Then click the arrows next to the Electric Currents , Heat Transfer in Solids , and Multiphysics  nodes to expand them.



The ‘D’ in the upper left corner of a node’s icon () means it is a default node.

The equations that COMSOL solves are displayed in the Equation section of the Settings windows of the respective physics nodes.

The default equation form is inherited from the study added in the Model Wizard. For Joule heating, COMSOL displays the equations solved for the temperature and electric potential.



-  To always display the equations in the Settings window, click the Show button () on the Model Builder toolbar and select Equation Sections so that a check mark appears next to it.

The Heat Transfer in Solids (*ht*) and Electric Currents (*ec*) nodes have the settings for heat conduction and current conduction, respectively.

Under the Electric Currents node, the Current Conservation node represents the conservation of electric current at the domain level and the Electric Insulation node contains the default boundary condition for Electric Currents.

Under the Heat Transfer in Solids node, the domain level Heat Transfer in Solids node represents the conservation of heat and the Thermal Insulation node contains the default boundary condition for Heat Transfer. The heat source for Joule heating is set in the Electromagnetic Heat Source node under the Multiphysics node. The Initial Values node, found in both the Electric Currents and Heat Transfer in Solids interfaces, contains initial guesses for the nonlinear solver for stationary problems and initial conditions for time-dependent problems.

Now, define the boundary conditions.

- 1 Right-click the Heat Transfer in Solids node . In the second section of the context menu—the boundary  section—select Heat Flux.

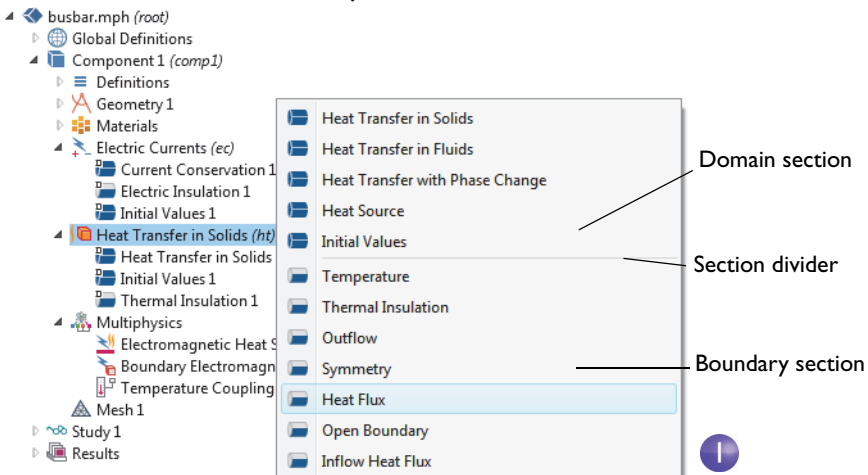
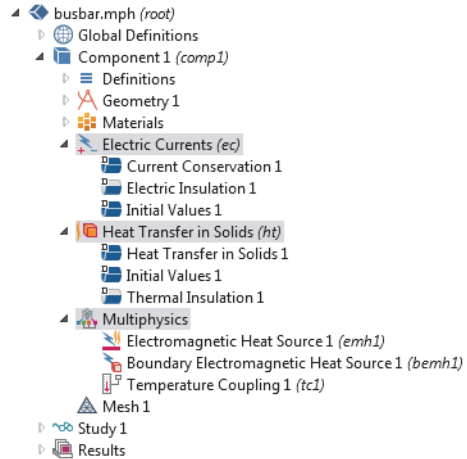

- 2 In the Settings window for Heat Flux, select All boundaries from the Selection list.

Assume that the circular bolt boundaries are neither heated nor cooled by the surroundings.

In the next step you will remove the selection of these boundaries from the heat flux selection list, which leaves them with the default insulating boundary condition for the Heat Transfer interfaces.

- 3 Rotate the busbar to view the back. Move the mouse pointer over one of the circular titanium bolt surfaces to highlight it in green. Click the bolt surface to remove this boundary selection from the Selection list. Repeat this step to remove the other two circular bolt surfaces from the selection list. Boundaries 8, 15, and 43 are removed.

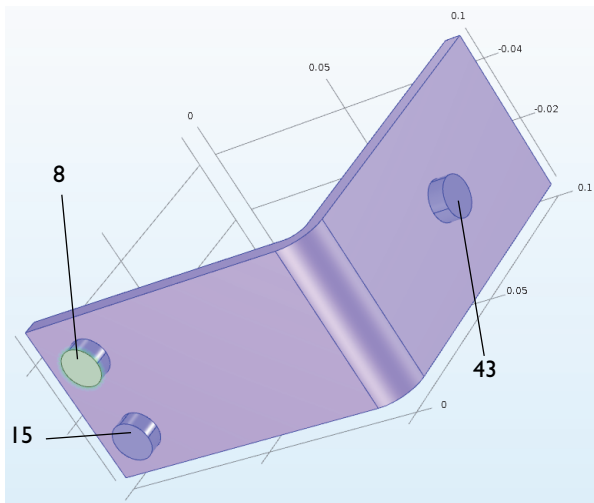
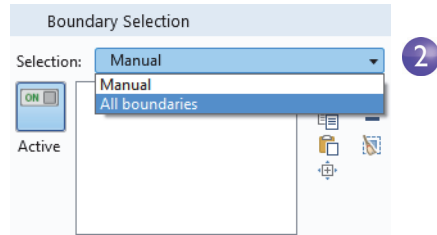

- 3 Cross-check: Boundaries 8, 15, and 43 are removed from the Selection list.



- In the Settings window for Heat Flux under Heat Flux, click the Convective heat flux button. Enter htc in the Heat transfer coefficient field, h .

This parameter was either entered in the Parameter table in “Global Definitions” on page 57 or imported with the geometry.

Continue by setting the boundary conditions for the electric current according to the following steps:

- In the Model Builder, right-click the Electric Currents node . In the second section of the context menu—the boundary section—select Electric Potential. An Electric Potential  node is added to the model tree.

▼ Heat Flux

General inward heat flux

Convective heat flux

$q_0 = h \cdot (T_{\text{ext}} - T)$

Heat transfer coefficient:

User defined ▼

Heat transfer coefficient:

h W/(m²·K)

External temperature:

T_{ext} K

Overall heat transfer rate

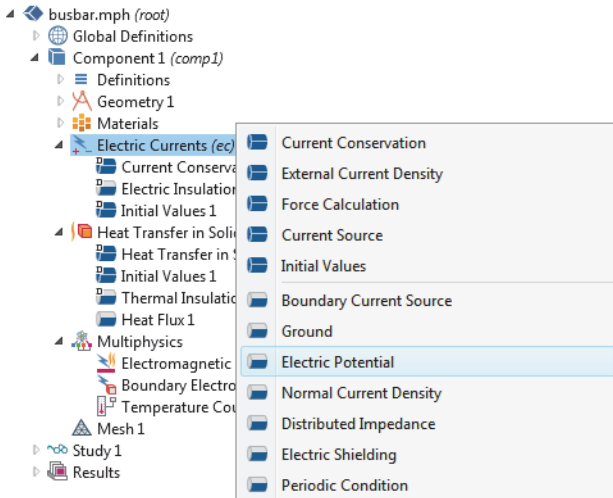

- 6 Move the mouse pointer over the circular face of the single titanium bolt to highlight it and then click to add it (boundary 43) to the Selection list.

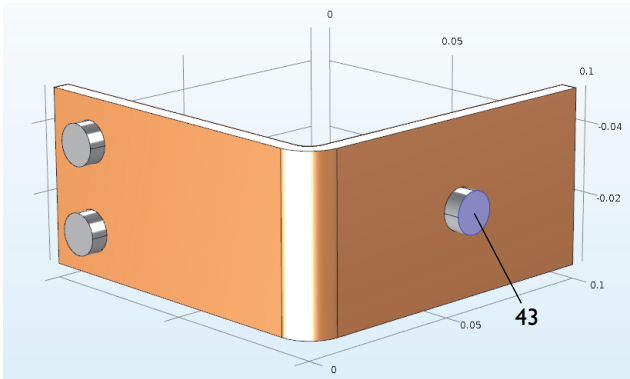

- 7 In the Settings window for Electric Potential enter V_{tot} in the Electric potential field.

The last step is to set the surfaces of the two remaining bolts to ground.

7

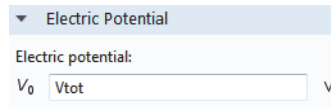

- 8 In the Model Builder, right-click the Electric Currents node . In the boundary section of the context menu, select Ground. A Ground node is added to the Model Builder. The model tree node sequence should now match this figure.

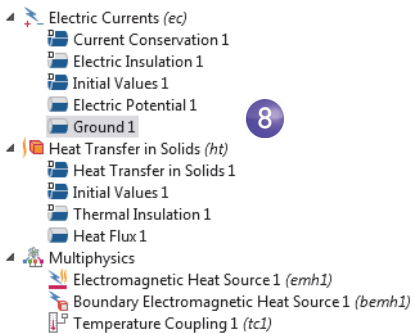

- 9 In the Graphics window, click one of the remaining bolts to add it to the Selection list.

9

Cross-check: Boundaries 8 and 15.

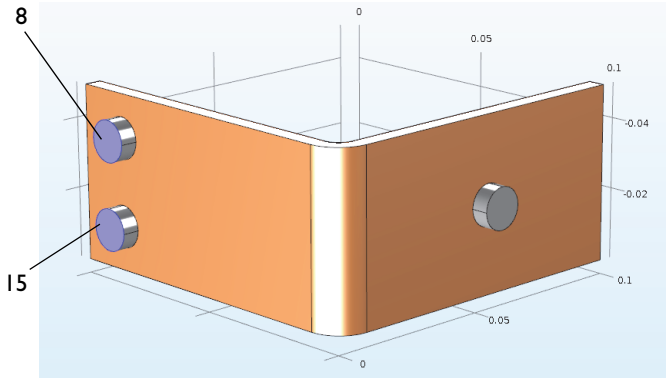

Repeat this step to add the last bolt. Boundaries 8 and 15 are added to the selection list for the Ground boundary condition.

- 10 On the Graphics toolbar, click the Go to Default 3D View button .

Graphics



10



As an alternative to using the preconfigured multiphysics interface for Joule heating, you can manually combine the Electric Currents and Heat Transfer in Solids interfaces. For example, you can start by setting up and solving the model for Electric Currents and then subsequently add Heat Transfer in Solids. In that case, you right-click the Multiphysics node to add the required multiphysics couplings.

Mesh

The simplest way to mesh is to create an unstructured tetrahedral mesh, which is perfect for the busbar. Alternatively, you can create several meshing sequences as shown in “Adding Meshes” on page 100.



A physics-controlled mesh is created by default. In most cases, it is possible to skip to the Study branch and just solve the model. For this exercise, the settings are investigated in order to parameterize the mesh settings.

1 In the Model Builder, click the Mesh 1 node . In the Settings window for Mesh, select User-controlled mesh from the Sequence type list.

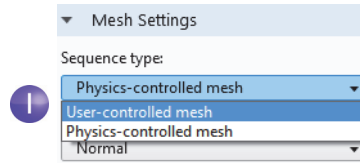

2 Under Mesh 1, click the Size node .



3 In the Settings window for Size under Element Size, click the Custom button.

Under Element Size Parameters, enter:

- mh in the Maximum element size field. Note that mh is 6 mm—the value entered earlier as a global parameter. By using the parameter mh , element sizes are limited to this value.
- $mh - mh/3$ in the Minimum element size field. The Minimum element size is slightly smaller than the maximum size.
- 0.2 in the Curvature factor field. The Curvature factor determines the number of elements on curved boundaries; a lower value gives a finer mesh.

3

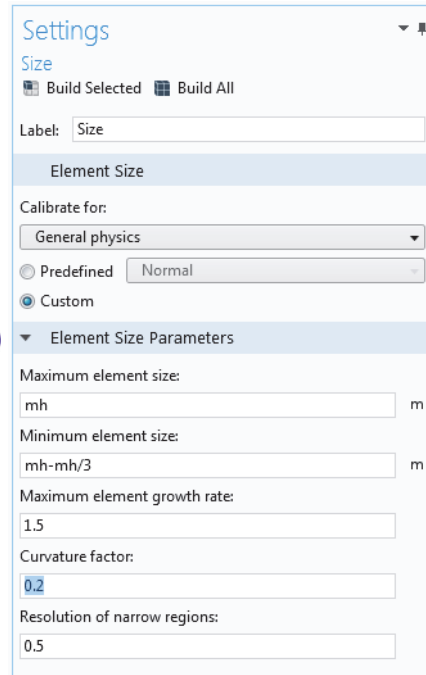

The other two parameters are left unchanged.

The Maximum element growth rate determines how fast the elements should grow from small to large over a domain. The larger this value is, the larger the growth rate. A value of 1 does not give any growth.

For Resolution of narrow regions, a higher value will in general result in a finer mesh.

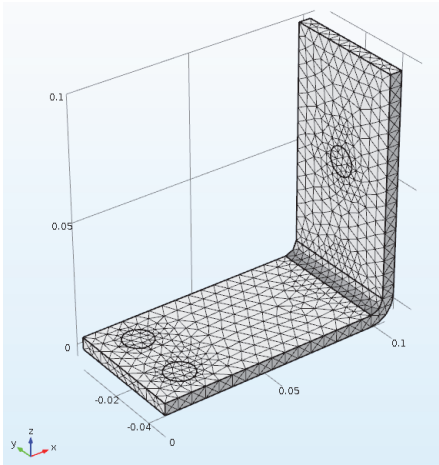

The asterisk (*) that displays in the upper-right corner of the Size node  indicates that the node is being edited.

- 4 Click the Build All button  in the Settings window for Size to create the mesh as in this figure:



You can also click Build Mesh in the Home tab of the ribbon.

Study

- 1 To run a simulation, in the Model Builder, right-click Study 1  and choose Compute . You can also press F8 or click Compute in the ribbon Home tab.

The Study node  automatically defines a solution sequence for the simulation based on the selected physics and the study type. The simulation only takes a few seconds to

solve. During the solution process, two Convergence plots are generated and are available from tabs next to the Graphics window. These plots show the convergence progress of the different solver algorithms engaged by the Study.

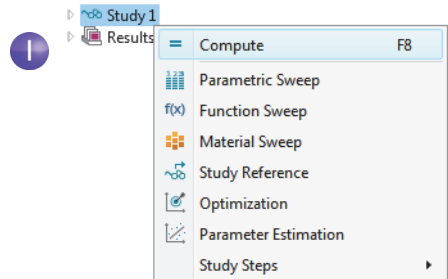





Results

By default, in the Results node, three plot groups are generated: a Multislice plot of the Electric Potential, a Surface plot of the Temperature, and a plot named Isothermal Contours containing an Isosurface plot of the temperature.

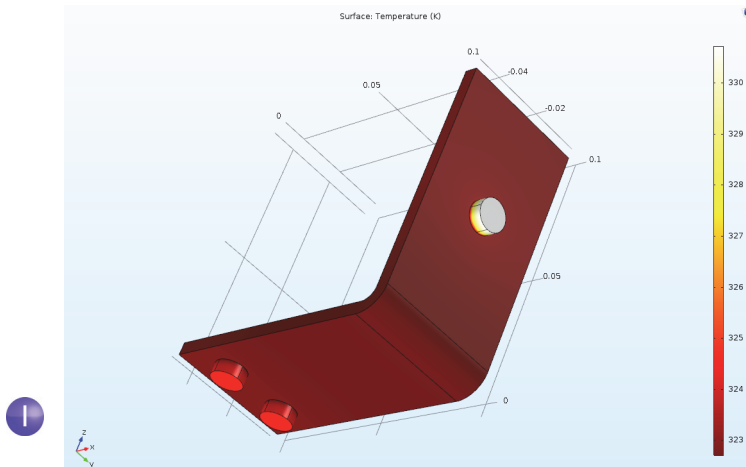
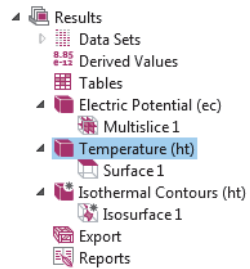
Click Results > Temperature  to view the temperature plot in the Graphics window. The temperature difference in the device is less than 10 K due to the high thermal conductivity of copper and titanium. The temperature variations are largest in the top bolt, which conducts double the amount of current compared to the two lower bolts. The temperature is substantially higher than the ambient temperature of 293 K.

- 1 Click and drag the image in the Graphics window to rotate and view the back of the busbar.



- 2 On the Graphics toolbar, click the Go to Default 3D View button . You can now manually set the color table range to visualize the temperature difference in the copper part.
- 3 In the Model Builder, expand the Results > Temperature node  and click the Surface 1 node .

- 4 In the Settings window for Surface click Range to expand the section. Select the Manual color range check box and enter 323 in the Maximum field (replace the default). Click the Plot button  on the Settings window for Surface.

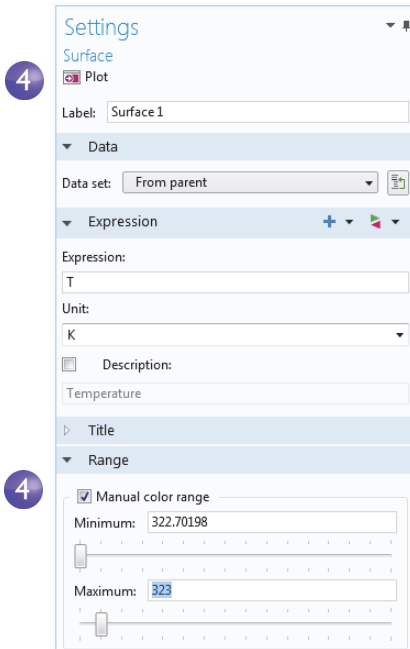

- 5 On the Graphics toolbar, click the Zoom Extents button  to view the updated plot.

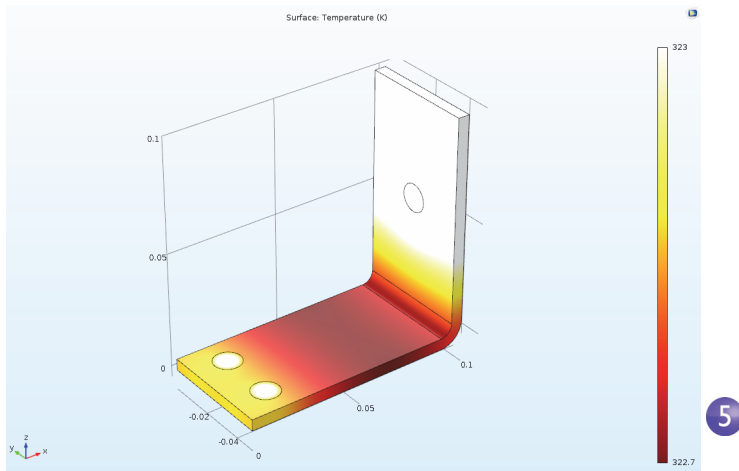



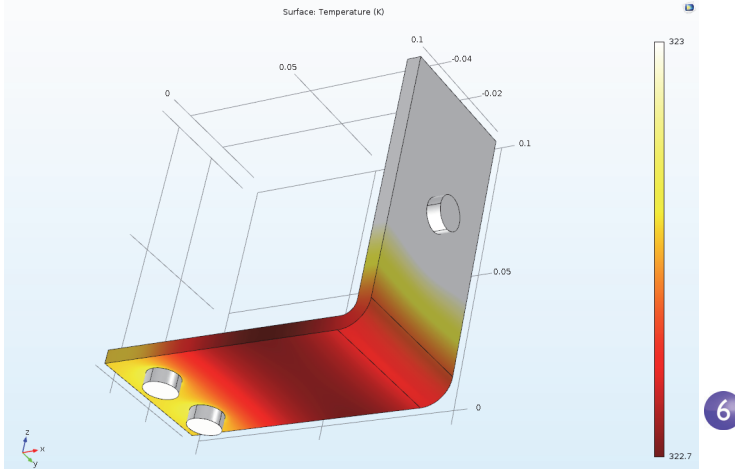

6 Click and drag in the Graphics window to rotate the busbar and view the back.





The temperature distribution is laterally symmetric with a vertical mirror plane running between the two lower titanium bolts and cutting through the center of the upper bolt. In this case, the model does not require much computing power and you can model the entire geometry. For more complex models, you can consider using symmetries to reduce the computational requirements.

Select Go to Default 3D View on the toolbar in the Graphics window .

Now, let us generate a Surface plot that shows the current density in the device.

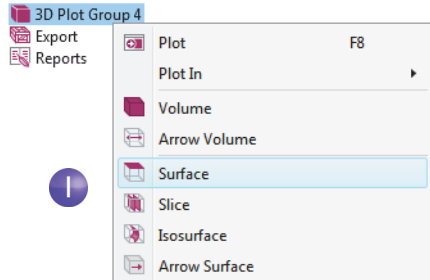
1 In the Model Builder, right-click Results  and add a 3D Plot Group . Right-click 3D Plot Group 4  and add a Surface node .



- In the Settings window for Surface under Expression, click the Replace Expression button . Go to Model>Component 1>Electric Currents > Currents and charge > `ec.normJ` -Current density norm and double-click or press Enter to select.

`ec.normJ` is the variable for the magnitude, or absolute value, of the current density vector. You can also enter `ec.normJ` in the Expression field when you know the variable name.

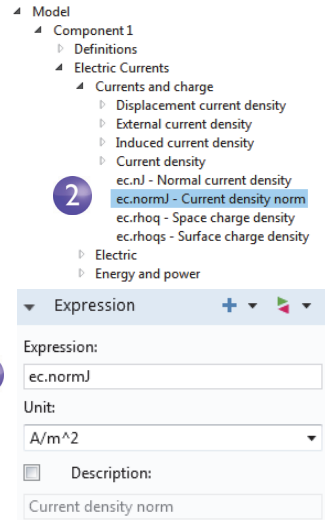

- Click the Plot button .

The plot that displays in the Graphics window is almost uniform in color due to the high current density at the contact edges with the bolts. The next step is to manually change the color table range to visualize the current density distribution.

- In the Settings window for Surface under Range, select the Manual color range check box. Enter $1e6$ in the Maximum field and replace the default.

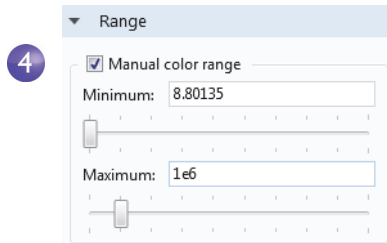

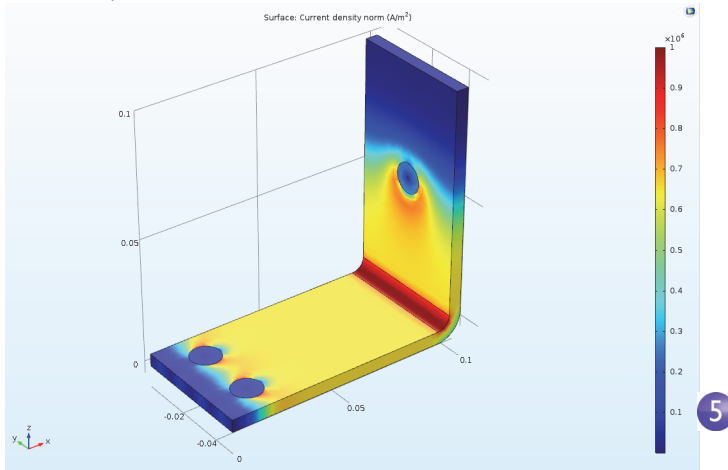

5 Click the Plot button .

The resulting plot shows that the current takes the shortest path in the 90-degree bend in the busbar. Notice that the edges of the busbar outside of the bolts are hardly utilized for current conduction.

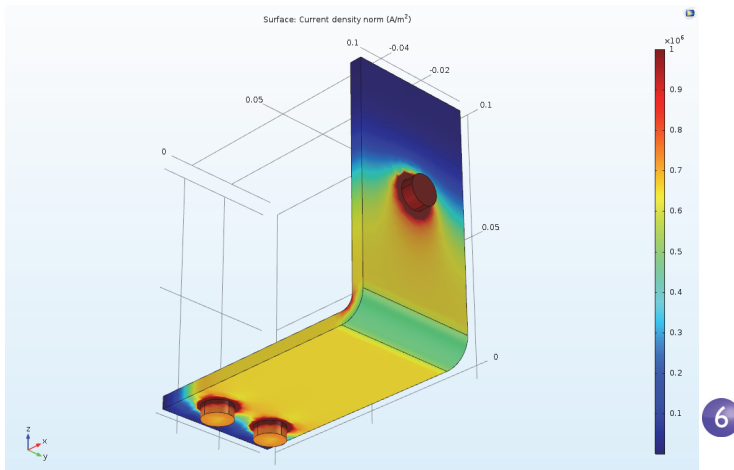

6 Click and drag the busbar in the Graphics window to view the back. Continue rotating the image to see the high current density around the contact surfaces of each of the bolts.





When you are done, click the Go to Default 3D View button  on the Graphics toolbar.

GETTING THE MAXIMUM AND MINIMUM TEMPERATURE

You can easily obtain the maximum and minimum temperature values in the busbar, including their locations.

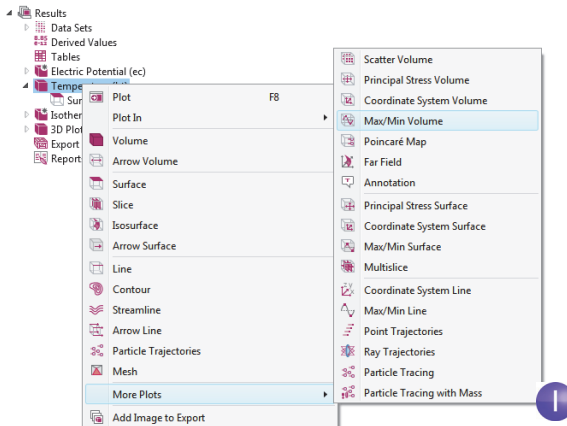
- 1 Right-click Results > Temperature  and select More Plots > Max/Min Volume.



- 2 In the Settings window for Max/Min Volume under Expression, click the Replace Expression button . Go to Model > Component 1 > Heat Transfer in Solids > Temperature > T - Temperature and double-click or press Enter to

select. You can also search for Temperature in the search field above the tree of postprocessing variables. Click Plot.

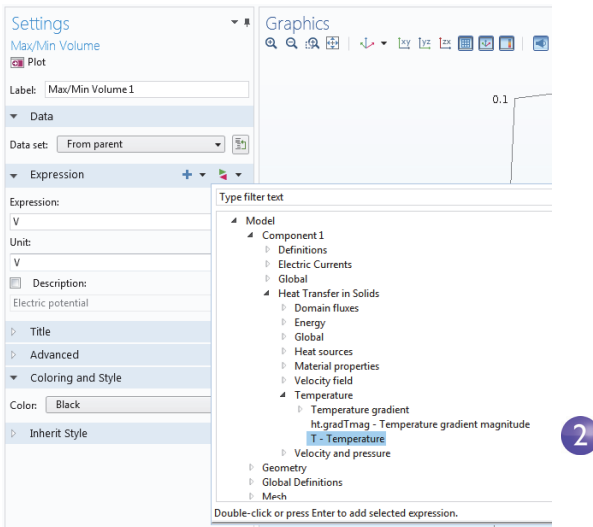

The maximum and minimum values are plotted in the Graphics window and their locations and values are displayed in the Maximum and minimum values table.

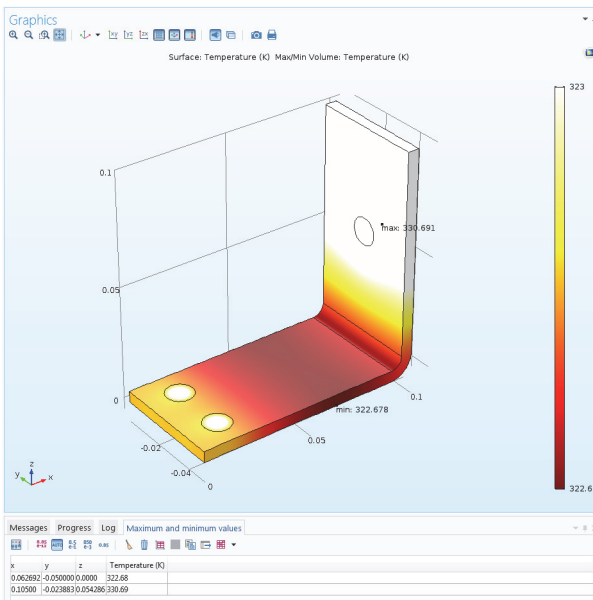

As an alternative to the method described above of plotting the maximum and minimum values, you can use the Derived Values node for a pure numerical output.

- 3 In the Results section of the model tree, right-click the Derived Values ^{0.85}_{0.12} node and select Maximum>Volume Maximum ^{MAX}.
- 4 In the Settings window for Volume Maximum, under Selection, choose All domains.
- 5 In the Expression text field enter T for the temperature and click Evaluate at the top of the Settings window.

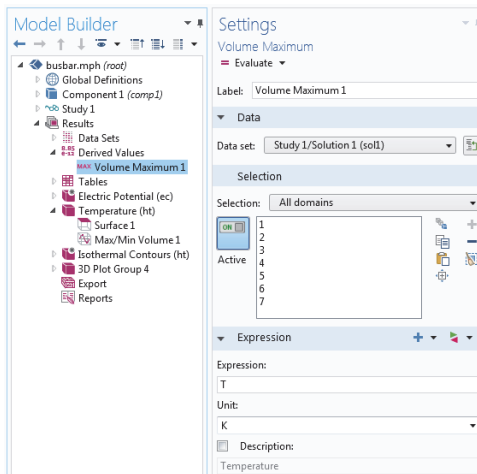

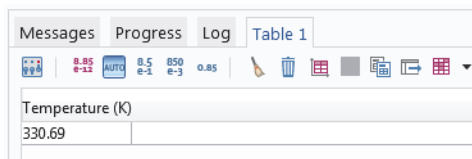

The resulting maximum temperature is shown in Table 1.



As a next step you will create a model thumbnail image.

CREATING MODEL IMAGES FROM PLOTS

With any solution, you can create an image to display in COMSOL when browsing for model files. After generating a Plot, in the Model Builder under Results, click the plot. Then click the root node (the first node in the model tree). In the Settings window for Root under Thumbnail, click Set from Graphics Window.

There are two other ways to create images from a plot. One is to click the Image Snapshot button  in the Graphics toolbar to directly create an image. You can also add an Image node  to an Export node to create an image file. Right-click the plot group of interest and then select Add Image to Export.

-  Make sure to save the model at this stage. This version of the model, busbar .mph, is reused and renamed during the next set of tutorials.

Creating an Application using the New Form Wizard

This section gives a brief introduction to creating an application based on the busbar model. The application will have a specialized user interface dedicated to interact with the busbar model and include input fields for the length, width, and applied voltage. The outputs will be the maximum temperature and a temperature plot.

You will learn how to use the New Form wizard to quickly create an application. The New Form wizard is used to create a form with user interface components called form objects. The wizard gives quick access to a subset of all the form objects available for creating applications with the Application Builder. In this example you will learn how to use the wizard to add input fields, numerical output, graphics, and buttons. For detailed information on building applications, see the book *Introduction to Application Builder*.

- I** To switch from the Model Builder to the Application Builder, click the Application Builder button in the leftmost part of the Home tab in the ribbon.

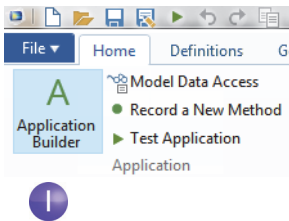

2 To create a new form, click the New Form button in the ribbon.

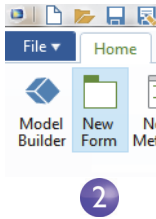

The wizard window now appears.

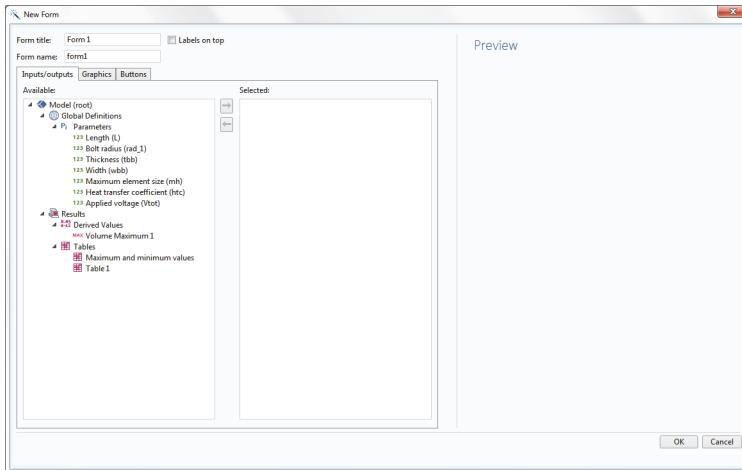

It consists of three tabs for Inputs/outputs, Graphics, and Buttons. In the Inputs/outputs tab you can double-click the nodes in the tree to make these available in the user interface of the application. For this application we will select a few of the parameters as input fields and the maximum temperature as output.

- 3 Double-click each of the Parameters: Length (L), Width (wbb), and Applied voltage (Vtot). Also, double-click the Volume Maximum under Derived Values.

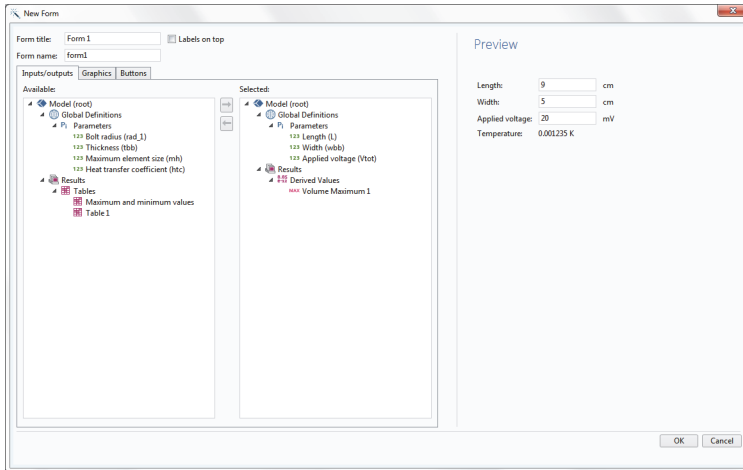

The Preview section to the right displays the user interface layout.

- 4 Click the Graphics tab in the wizard and double-click the Temperature plot. A graphics object placeholder appears in the Preview area.

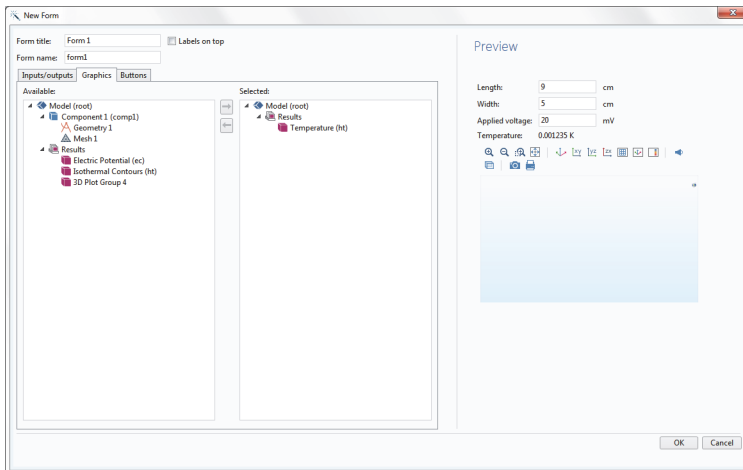

- 5 Click the Buttons tab in the wizard and double-click Compute Study 1. A button now appears in the Preview area beneath the graphics object.

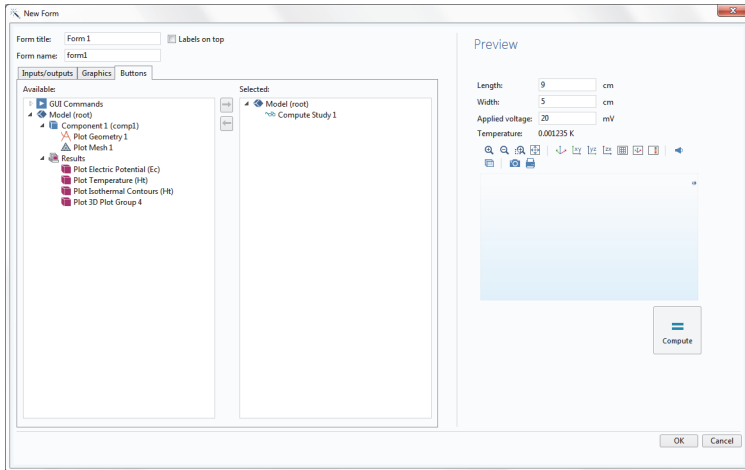

- 6 Finally, click OK to accept the settings and close the wizard.

After closing the New Form wizard, the Form editor is opened. The Form editor allows you to drag-and-drop form objects and add new ones

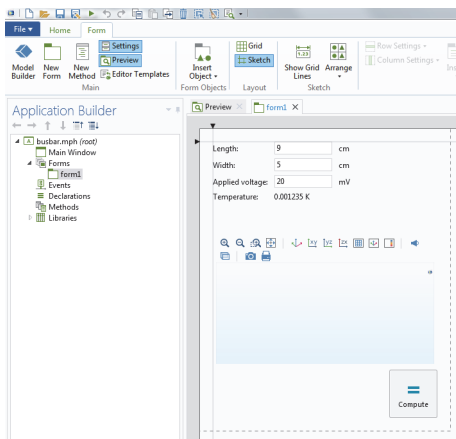

- 7 You can, for example, rearrange the user interface by placing the graphics object to the right of the input fields and the button directly under the input fields, as shown in the figure below. Blue guide lines will aid you in aligning the objects.

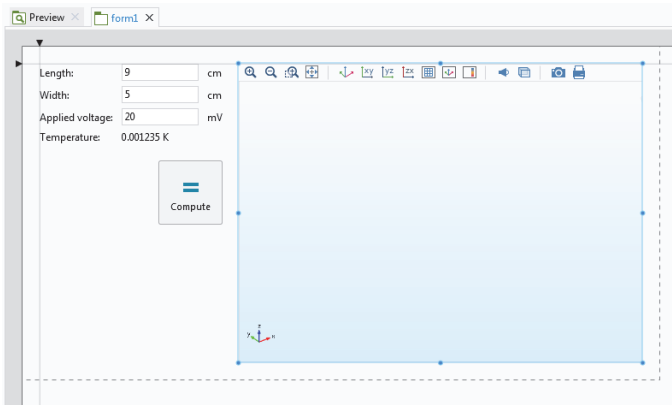

You can make the graphics object larger by dragging the blue handles.

- 8 You can test the application by clicking Test Application in the ribbon.

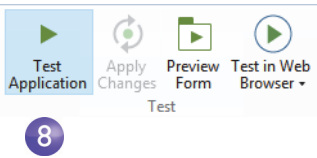

This creates a run-time copy of the application and lets you quickly try different designs during the process of developing an application.

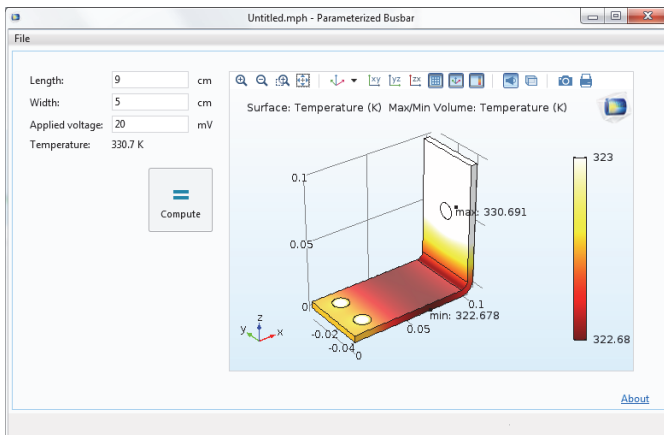

9 Now, try a different Length value and click Compute.

You may wish to preview the geometry before starting the computation and this can easily be done by adding a button. There are two ways of adding a button. Either use the Insert Object menu in the ribbon, as shown in the figure below or use the Editor Tools window. In this example, you will use the latter.

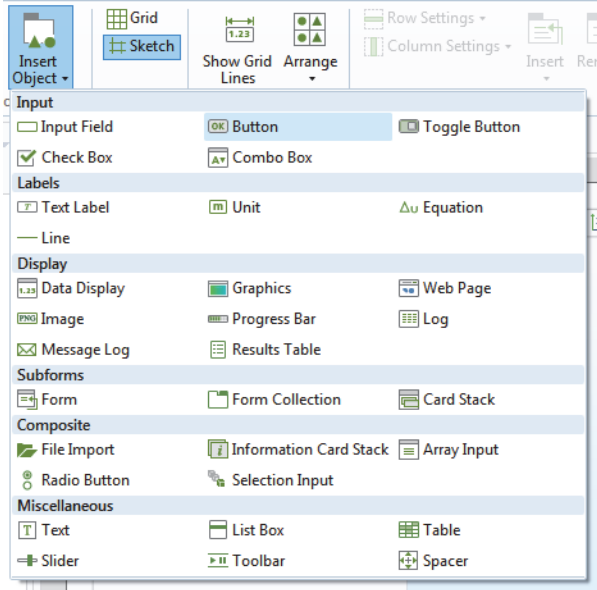

1 First, make sure the Editor Tools window is visible by selecting the corresponding button in the ribbon.

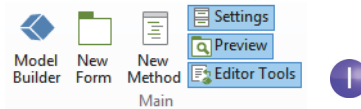

2 In the Editor Tools tree, right-click the Geometry node and select Button.

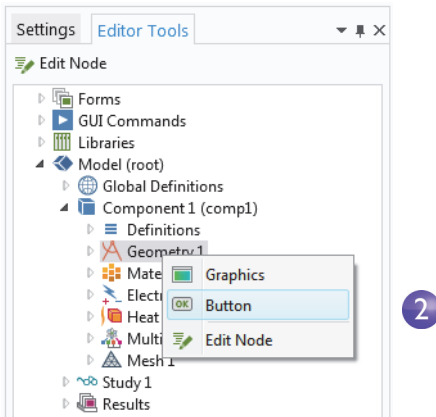

3 Drag the Plot Geometry button to the left of the Compute button.

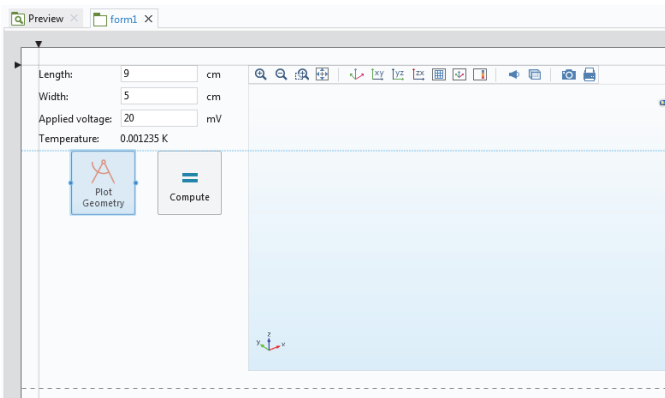

Behind each button is a command sequence that controls the action taken when it is pressed. The command sequence is defined in the Settings window of the button and you can open the Settings window (if not already opened) by double-clicking the button.

- 4 Double-click the Plot Geometry button to see its Settings window. Command sequences appear below the tree in the section Choose Commands to Run.

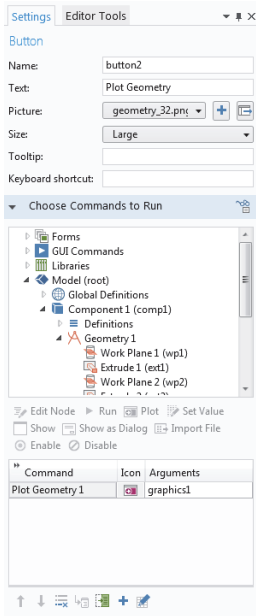

In this case, the command sequence for the Plot Geometry has one command for plotting the geometry. The input argument contains information on which graphics window to send the geometry plot. In this case the graphics object graphics1.

To automatically adjust the axis settings, you can add a Zoom Extents command.

- 5 In the Choose Commands to Run section, locate the Zoom Extents command under GUI Commands > View Commands. Double click to add it to the command sequence.

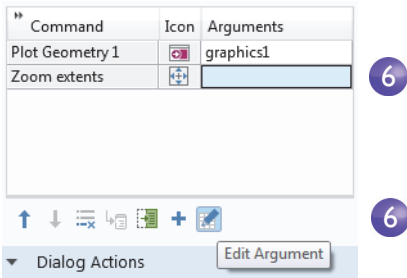

- 6 Now create the input argument to the Zoom Extents command. Click the white field next to Zoom extents and click the Edit Argument button.

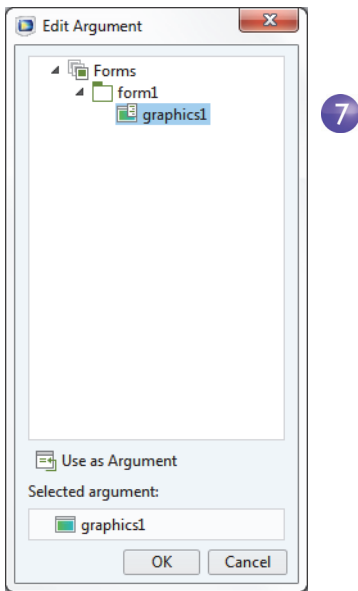

- 7 This opens a dialog box with possible input arguments. Select graphics1 under form1.



8 The command sequence is now complete.

Command	Icon	Arguments
Plot Geometry 1		graphics1
Zoom extents		form1/graphics1

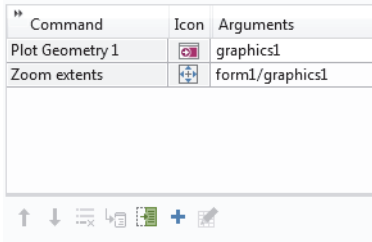

9 To make sure the new Plot Geometry button works, you can now test the application again by clicking Test Application in the ribbon.

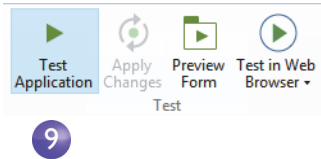

To perform more advanced operations than what is possible to do with a command sequence, you can use the Method editor to write code that defines the actions to be taken when the user clicks a button. An easy way to get started with the Method editor is to convert an existing command sequence into a method.

1 Locate or open the Settings window for the Plot Geometry button again. Click the Convert to New Method button below the command sequence.

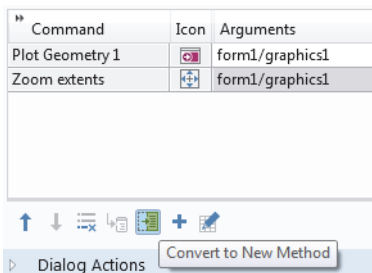

- 2 To open the method in the Method editor, click the Go to Method button below the command sequence.

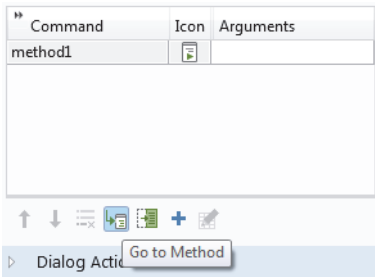

2

The Method editor now opens with the code for method1 corresponding to the Plot Geometry and the Zoom Extents commands in the previous command sequence.

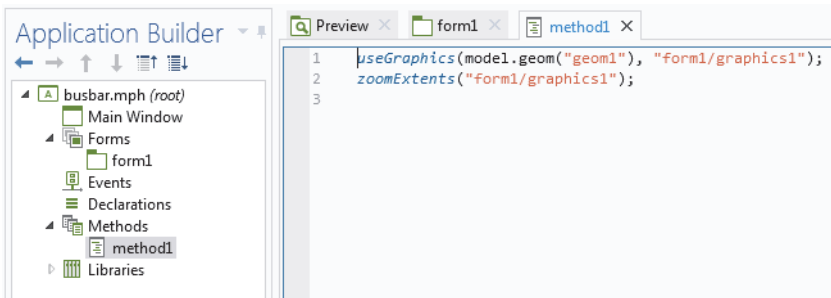

2

The Application Builder has several tools for automatically generating code. In addition to converting a command sequence to a method, you can, for example, click Record Code in the ribbon.



This will automatically switch over to the Model Builder and generate code for each operation performed there. Click Stop Recording in the ribbon to stop recording and go back to the Method Editor.

To learn more about using the Form Editor and the Method Editor, see the book *Introduction to Application Builder*.

This completes the Busbar example. To switch back to the Model Builder click the Model Builder button in the ribbon.

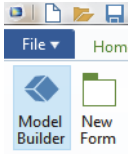

The next sections are designed to deepen your understanding of the steps implemented so far, and to extend your simulation to include additional effects like thermal expansion and fluid flow. These additional topics begin on the following pages:

- “Parameters, Functions, Variables and Couplings” on page 94
- “Material Properties and Material Libraries” on page 98
- “Adding Meshes” on page 100
- “Adding Physics” on page 102
- “Parametric Sweeps” on page 123
- “Parallel Computing” on page 132
- “Appendix A—Building a Geometry” on page 136

Advanced Topics

Parameters, Functions, Variables and Couplings

This section explores working with Parameters, Functions, Variables, and Component Couplings.



Global Definitions and Component Definitions contain functionality that help you to prepare model inputs and component couplings, and to organize simulations. You have already used the functionality for adding Parameters to organize model inputs in “Global Definitions” on page 57.

Functions, available as both Global Definitions and Component Definitions, contain a set of predefined function templates that can be useful when setting up multiphysics simulations. For example, the Step function template can create a smooth step function for defining different types of spatial or temporal transitions.

To illustrate using functions, assume that you want to add a time dependent study to the busbar model where an electric potential is applied across the busbar that goes from 0 V to 20 mV in 0.5 seconds. For this purpose, you could use a step function to be multiplied with the parameter V_{tot} . In this section, you’ll add a step function to the model that goes smoothly from 0 to 1 in 0.5 seconds to find out how functions can be defined and verified.

DEFINING FUNCTIONS

For this section, you can continue working with the same model file created in the previous section. Locate and open the file `busbar.mph` if it is not already open on the desktop.

- 1 Right-click the Global Definitions node  and select Functions>Step .

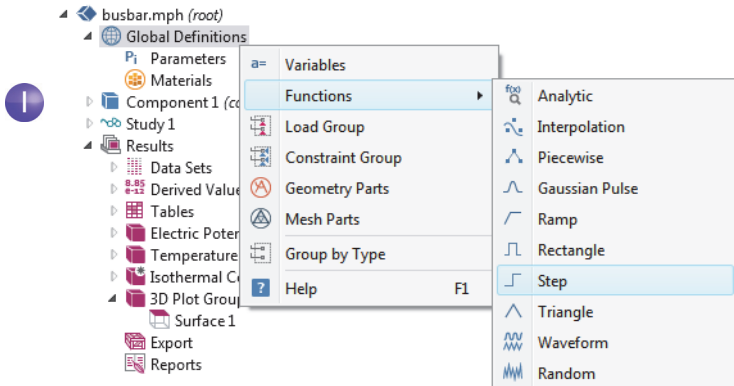

- 2 In the Settings window for Step enter 0.25 in the Location field to set the location of the middle of the step, where it has the value of 0.5.

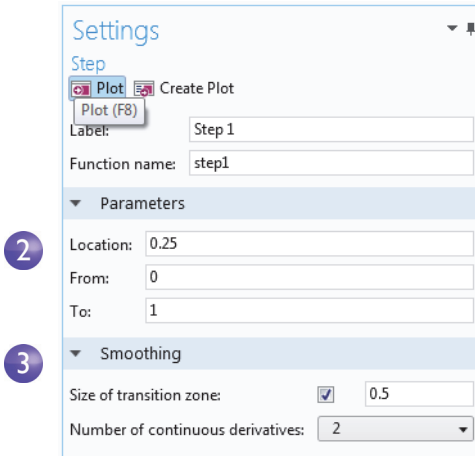

- 3 Click Smoothing to expand the section and enter 0.5 in the Size of transition zone field to set the width of the smoothing interval. Keep the default Number of continuous derivatives at 2.
- 4 Click the Plot button  in the Settings window for Step.

If your plot matches the one below, this confirms that you have defined the function correctly.

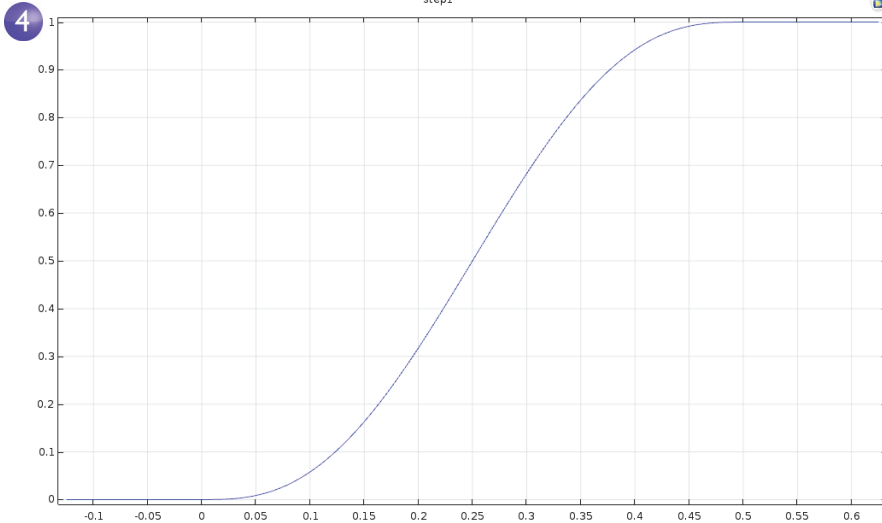

You can also add comments and rename the function to make it more descriptive.

5 Right-click the Step 1 node in the Model Builder and select Properties.

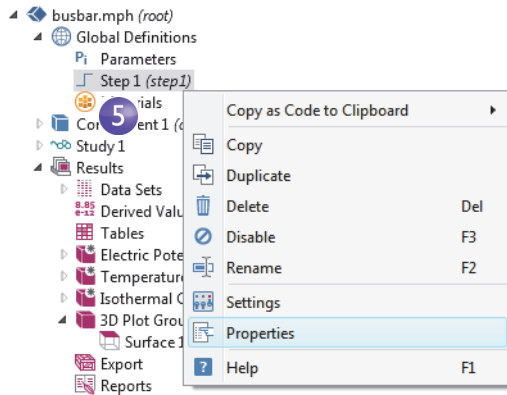

- 6 In the Properties window, enter any information you want. Right-click the Properties tab and select Close when you are finished.

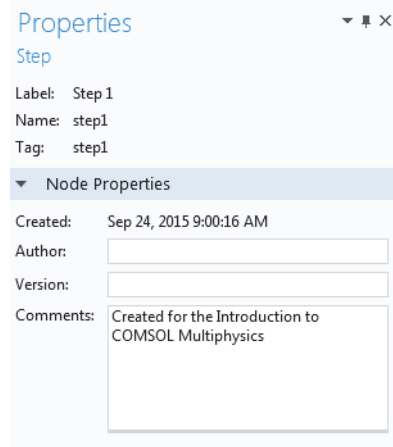

For the purpose of this exercise, assume that you want to introduce a second component to represent an electric device connected to the busbar through the titanium bolts.

A first step would be to rename Component 1 to specify that it represents the busbar.

- 1 Right-click the Component 1 node and select Rename (or press F2).
- 2 In the Rename Component window, enter Busbar. Click OK and save the model.

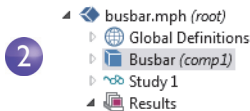

DEFINING COMPONENT COUPLINGS



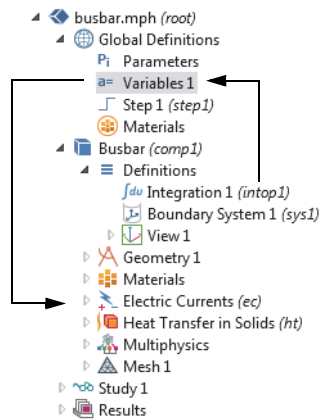

Right-click the Definitions node under Busbar (comp1) to introduce a Component Coupling that computes the integral of any Busbar (comp1) variable at the bolt boundaries facing the electric device. You can use such a coupling, for example, to define a Variable in the Global Definitions node that calculates the total current. This variable is then globally accessible and could, for example, form a boundary condition for the current that is fed to an electric device modeled as a second component.

The Component Couplings in Definitions have a wide range of uses. The Average \bar{av} ,



Maximum ^{MAX}, and Minimum ^{MIN} couplings have applications in generating results as well as in boundary conditions, sources, sinks, properties, or any other contribution to the model equations. The Probes  are for monitoring the solution progress. For instance, you can follow the solution at a critical point during a time-dependent simulation, or for each parameter value in a parametric study.

You can find an example of using the average operator in “Parametric Sweeps” on page 123. Also see “Functions” on page 160 for a list of available COMSOL functions.

 To learn more about working with definitions, in the Model Builder, click the Definitions  or Global Definitions  node and press F1 to open the Help window . This window displays helpful information about the selected item in the desktop and provides links to the documentation. It could take up to a minute for the window to load the first time it is activated, but will load quickly the next time it is opened.

Material Properties and Material Libraries

You have already used the functionality in Materials to access the properties of copper and titanium in the busbar model. In Materials, you are also able to define your own materials and save them in your material library. You can also add material properties to existing materials. In cases where you define properties that are functions of other variables, typically temperature, the plot functionality helps you to verify the property functions in the range of interest. You can also load Excel[®] spreadsheets and define interpolation functions for material properties using LiveLink[™] for Excel[®].

The Material Library add-on contains over 2500 materials with tens of thousands of temperature-dependent property functions.

First investigate how to add properties to an existing material. Assume that you want to add bulk modulus and shear modulus to the copper properties.

CUSTOMIZING MATERIALS

Let us keep working on the busbar.

1 In the Model Builder, under Materials, click Copper .

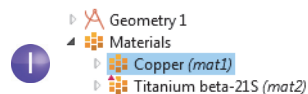

- 2 In the Settings window for Material, click to expand the Material Properties section, which contains a list of all the definable properties.

Expand the Solid Mechanics > Linear Elastic Material section. Right-click Bulk Modulus and Shear Modulus and select + Add to Material.

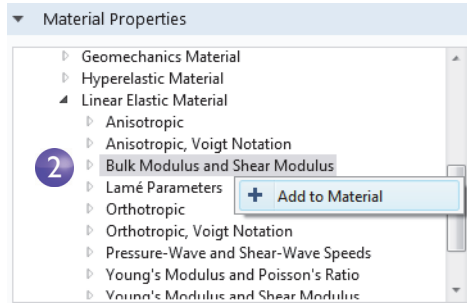

This lets you define the bulk modulus and shear modulus for the copper in your model.

- 3 Locate the Material Contents section. Bulk modulus and Shear modulus rows are now available in the table. The warning sign ⚠ indicates that the values are not yet defined. To define the values, click the Value column. In the Bulk modulus row, enter 140e9 and in the Shear modulus row, enter 46e9.

Property	Name	Value	Unit	Property group
Bulk modulus	K	140e9	N/m ²	Bulk modulus and shear mod...
⚠ Shear modulus	G	46e9	N/m ²	Bulk modulus and shear mod...
<input checked="" type="checkbox"/> Electrical conductivity	sigma	5.998e7[S/...	S/m	Basic
<input checked="" type="checkbox"/> Heat capacity at constant pressure	Cp	385[J/(kg*...	J/(kg·K)	Basic
<input checked="" type="checkbox"/> Relative permittivity	epsilon	1	1	Basic
<input checked="" type="checkbox"/> Density	rho	8700[kg/m...	kg/m ³	Basic
<input checked="" type="checkbox"/> Thermal conductivity	k	400[W/(m...	W/(m·K)	Basic
Relative permeability	mur	1	1	Basic
Coefficient of thermal expansion	alpha	17e-6[1/K]	1/K	Basic
Young's modulus	E	110e9[Pa]	Pa	Young's modulus and Poisson...
Poisson's ratio	nu	0.35	1	Young's modulus and Poisson...
Reference reactivity	rho0	1.72e-8[ob...	0...	Linearized reactivity...

By adding these material properties, you have changed the Copper material. You can save this information in your own material library, but not in the read-only Solid Mechanics materials library.

- 4 In the Model Builder, right-click Copper and select “Add to User-Defined Library” .

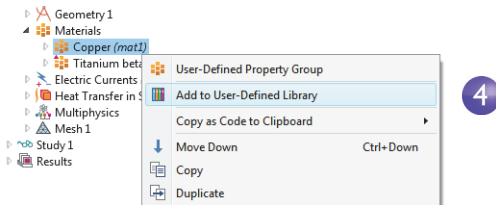



Adding Meshes

A model component can contain different meshing sequences for generating meshes with different settings. These sequences can then be accessed by the study steps. In the study, you can select which mesh you would like to use in a particular simulation.

In the busbar model, a second mesh node is now added to create a mesh that is refined in the areas around the bolts and the bend.

ADDING A MESH

- 1 Open the model `busbar.mph` that was created earlier.
- 2 In order to keep this model in a separate file for later use, select File > Save As and rename the model `busbar_I.mph`.
- 3 To add a second mesh node, right-click the Component 1 (`comp1`) node  and select Add Mesh .

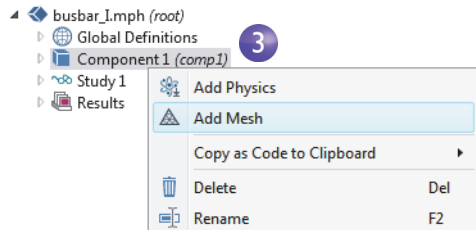

By adding another Mesh node, a Meshes parent node is created that contains both Mesh 1 and Mesh 2.

- 4 Click the Mesh 2 node. In the Settings window for Mesh under Mesh Settings, select User-controlled mesh as the Sequence type.

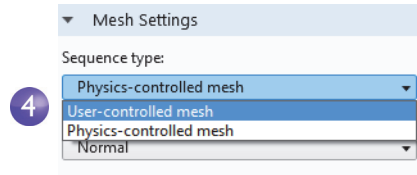

A Size and Free Tetrahedral node are added under Mesh 2.

- 5 In the Model Builder, under Mesh 2, click Size .

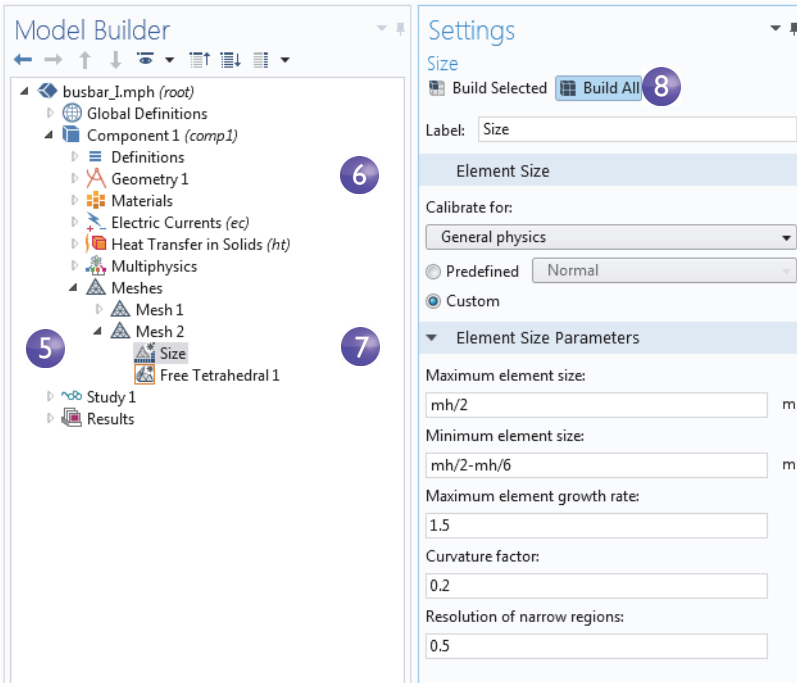

The asterisk in the upper-right corner of a node icon indicates that the node is being edited.

- 6 In the Settings window for Size, under Element Size, click the Custom button.
- 7 Under Element Size Parameters, enter:
 - $mh/2$ in the Maximum element size field, where mh is 6 mm—the mesh control parameter defined previously.
 - $mh/2 - mh/6$ in the Minimum element size field.
 - 0.2 in the Curvature factor field.
- 8 Click Build All . Save the file busbar_I.mph.

Compare Mesh 1 and Mesh 2 by clicking the Mesh nodes. The mesh is updated in the Graphics window. An alternative to using many different meshes is to run a parametric sweep of the parameter for the maximum mesh size, m_h , that was defined in the section “Global Definitions” on page 57.

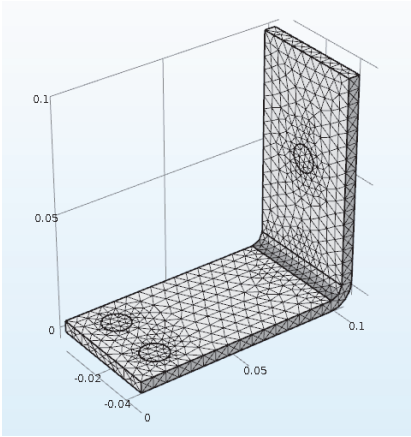

Mesh 1

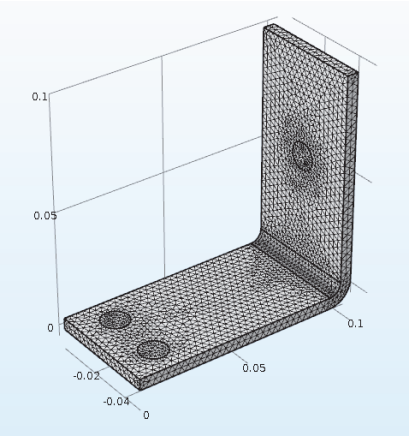

Mesh 2

Adding Physics

The distinguishing characteristics of COMSOL, particularly adaptability and compatibility, are prominently displayed when you add physics to an existing model. In this section, you will understand the ease with which this seemingly difficult task is performed. By following these directions, you can add structural mechanics and fluid flow to the busbar model.

STRUCTURAL MECHANICS

After completing the busbar Joule heating simulation, we know that there is a temperature rise in the busbar. What kind of mechanical stress is induced by thermal expansion? To answer this question, let us expand the model to include the physics associated with structural mechanics.

❗ To complete these steps, either the Structural Mechanics Module or the MEMS Module (which enhances the core Solid Mechanics interface) is required.

If you want to add cooling by fluid flow, or don't have the Structural Mechanics Module or MEMS Module, read this section and then go to “Cool by Adding Fluid Flow” on page 109.

1 Open the model `busbar.mph` that was created earlier. From the main menu, select `File > Save As` and rename the model `busbar_II.mph`.

2 In the Model Builder, right-click the Component 1 node and select `Add Physics`.

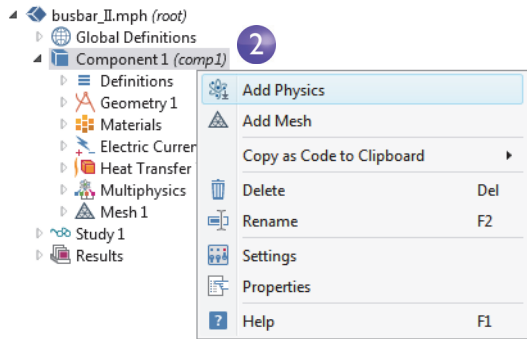

3 In the Add Physics window, under Structural Mechanics, select `Solid Mechanics`.

To add this interface, you can right-click and select `Add to Component` or click the `+ Add to Component` button at the top of the window.

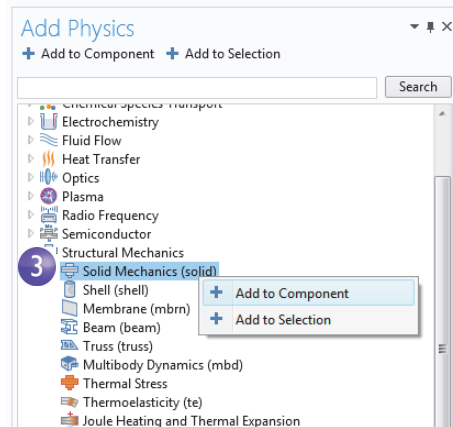

4 Close the Add Physics window and save the file.



❗ When adding additional physics, you need to make sure that materials included in the Materials node have all the required properties for the

selected physics. In this example, you already know that all properties are available for copper and titanium.

You can start by adding the effect of thermal expansion to the structural analysis.

5 In the Model Builder right-click the Multiphysics node  and select Thermal Expansion .

A Thermal Expansion node is added to the Model Builder.

You can also use the ribbon and select, from the Physics tab, Multiphysics > Thermal Expansion.

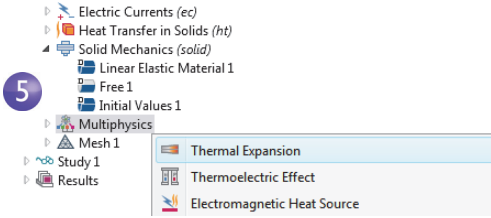

- 6 In the Settings window for Thermal Expansion, from the Selection list select All domains. This will enable thermal expansion in the copper as well as in the titanium bolts.

The Thermal Expansion Properties section of this window shows information about the Coefficient of thermal expansion and the Strain reference temperature. The Coefficient of thermal expansion takes its value from the Materials node. The Strain reference temperature has a default value of 293.15 K (room temperature) and defines the temperature for which there is no thermal expansion. The Thermal Expansion section at the bottom of the Settings windows shows which two physics interfaces define the physics for heat transfer and solid mechanics. This is useful in the case where there are more than one physics interface for heat transfer or solid mechanics in the model component. Keep all default settings in this window.

6

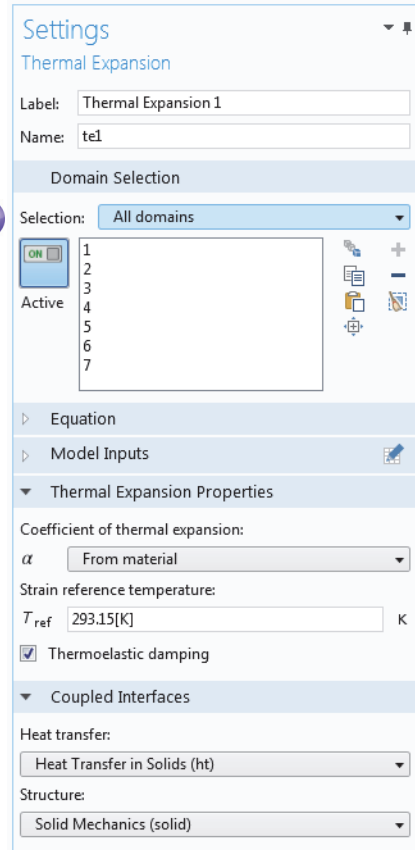

Next, constrain the busbar at the position of the titanium bolts.

- 7 In the model tree, right-click Solid Mechanics and from the boundary level, select Fixed Constraint . A node with the same name is added to the tree.
- 8 Click the Fixed Constraint node . In the Graphics window, rotate the busbar to view the back. Click the circular surface of one of the bolts to add it to the Selection list.

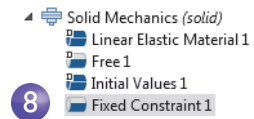

9 Repeat this procedure for the remaining bolts to add boundaries 8, 15, and 43.

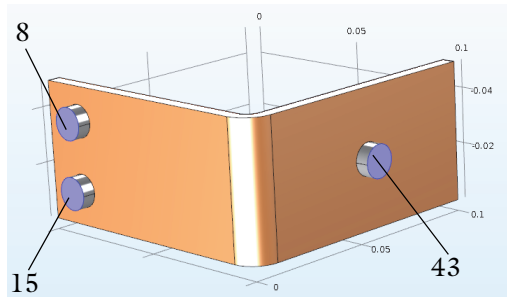
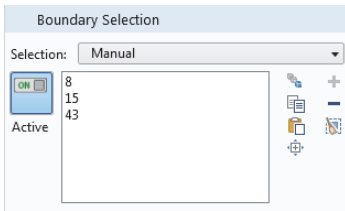

9



For easier management of multiple boundary selections, you can group boundaries into a user-defined Selection. Once you have selected boundaries 8, 15, and 43, click the Create Selection button  and give it a name such as Bolt top surfaces.

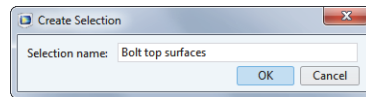

This Selection is then added as a node under Component 1>Definitions and is accessible from the Selection list for all types of boundary conditions. You can use this technique to group Domains, Boundaries, Edges, and Points.

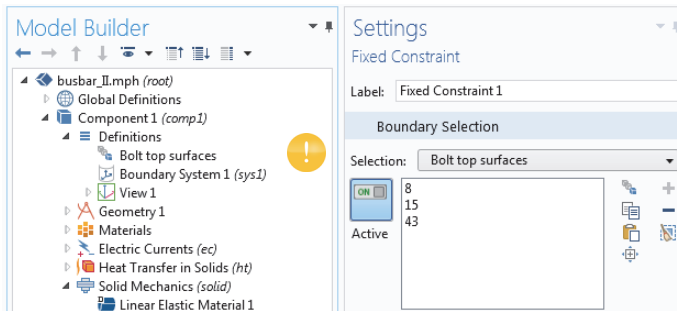

Next we update the Study to take the added physics into account.

SOLVING FOR JOULE HEATING AND THERMAL EXPANSION

The Joule heating effect is independent of the stresses and strains in the busbar, assuming small deformations and ignoring the effects of electric contact pressure. This means that you can run the simulation using the temperature as input to the structural analysis. In other words, the extended multiphysics problem is weakly

coupled. As such, you can solve it in two separate study steps to save computation time—one for Joule heating and a second one for structural analysis.

- 1 In the Model Builder, right-click Study 1 and select Study Steps > Stationary > Stationary to add a second stationary study step.

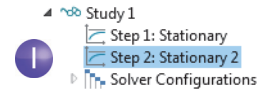

! When adding study steps you need to manually connect the correct physics with the correct study step. We shall start by disabling the structural analysis from the first step.

- 2 Under Study 1, click the Step 1: Stationary node.
- 3 In the Settings window for Stationary, locate the Physics and Variables Selection.

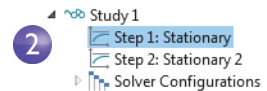

- 4 In the Solid Mechanics (solid) row under Solve for, click to change the check mark to an empty box to remove Solid Mechanics from Study Step 1.

4

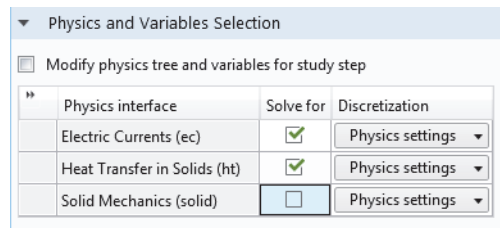

Now repeat these steps to remove Electric Currents (ec) and Heat Transfer in Solids (ht) from the second study step.

- 5 Under Study 1, click Step 2: Stationary 2.

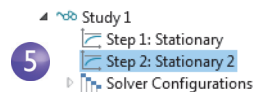

- 6 Under Physics and Variables Selection, in the Electric Currents (ec) and Heat Transfer in Solids (ht) rows, click to change the check mark to an empty box to remove Joule heating from Study Step 2.

6

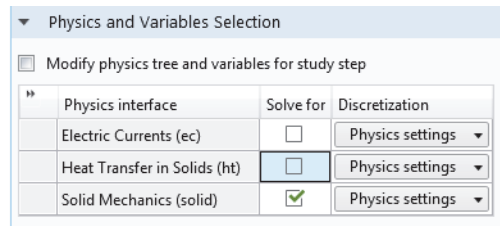

7 Right-click the Study 1 node  and select Compute = (or press F8 or click Compute in the ribbon) to solve.

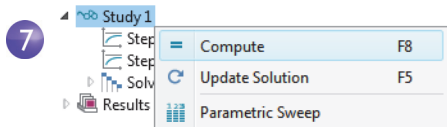



Save the file `busbar_II.mph`, which now includes the Solid Mechanics interface and the additional study step.

RESULTING DEFORMATION

Now add a displacement plot.

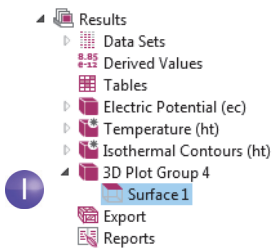
1 Under Results>3D Plot Group 4, click the Surface 1 node .



- 2 In the Settings window for Surface in the Expression section, click the Replace Expression button .

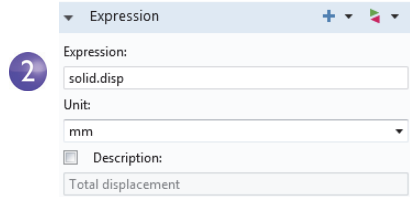

From the context menu, select Model>Component 1>Solid Mechanics> Displacement> solid.disp - Total displacement.

You can also enter `solid.disp` in the Expression field.

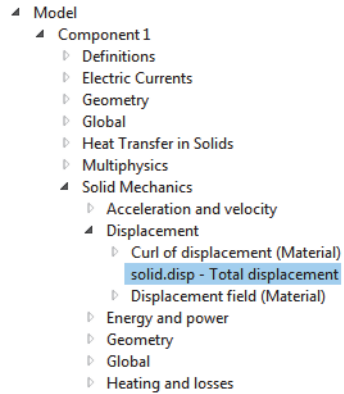

Now, change to a more suitable unit. In the Settings window under Expression, from the Unit list select mm (or type mm in the field).

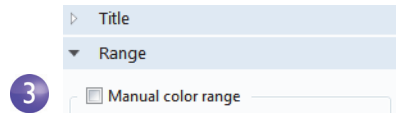

- 3 Click Range to expand that section. Click to clear the Manual color range check box.



The local displacement due to thermal expansion is displayed by COMSOL as a surface plot. Next we'll add information about the busbar deformation.

- 4 In the Model Builder, under Results>3D Plot Group 4, right-click the Surface 1 node  and add a Deformation node . The plot automatically updates in the Graphics window. Click the Go to Default 3D View button  so your view appears similar to the plot shown below.



The deformations shown in the figure are highly amplified to make the very small distortions that actually take place more visible.

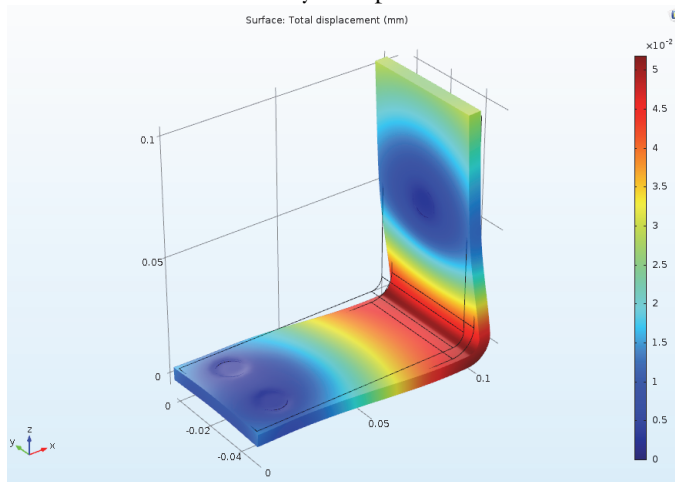

5 Save the `busbar_II.mph` file, which now includes a Surface plot with a Deformation.



You can also plot the von Mises and principal stresses to assess the structural integrity of the busbar and the bolts.

COOL BY ADDING FLUID FLOW

After analyzing the heat generated in the busbar and possibly the induced thermal expansion, you might want to investigate ways of cooling the busbar by letting air flow over its surfaces. These steps do not require any additional modules as the model only includes Joule heating without the previous thermal expansion analysis.



If you have the CFD Module, the Non-Isothermal Flow multiphysics interface is available. If you have the Heat Transfer Module, the Conjugate Heat Transfer multiphysics interface is available. Either one of these two interfaces automatically defines coupled heat transfer in solids and fluids including laminar or turbulent flow, whereas in this example, this is done manually and with limited functionality.

Adding fluid flow to the Joule heating model forms a new multiphysics coupling. To simulate the flow domain, you need to create an air box around the busbar. You can do this manually by altering the geometry from your first model or by opening an application library file. In this case, you will open a file with the box already created.

After loading the geometry, you will learn how to simulate air flow according to this figure:

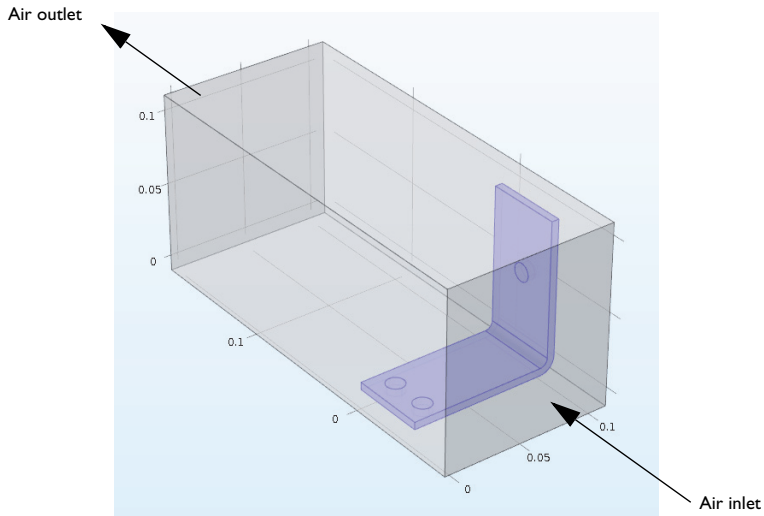

DEFINING INLET VELOCITY

Start by loading the geometry and adding a new parameter for the inlet flow velocity.

- | If you have just reopened the software, close the New window that opens automatically by clicking the Cancel button .

- 2 Click the Home tab, and from the Windows menu select Application Libraries . Navigate to COMSOL Multiphysics> Multiphysics> busbar box.

Double-click to open the file, which contains the geometry in addition to the physics modeling steps completed through the end of the section “Customizing Materials” on page 98.

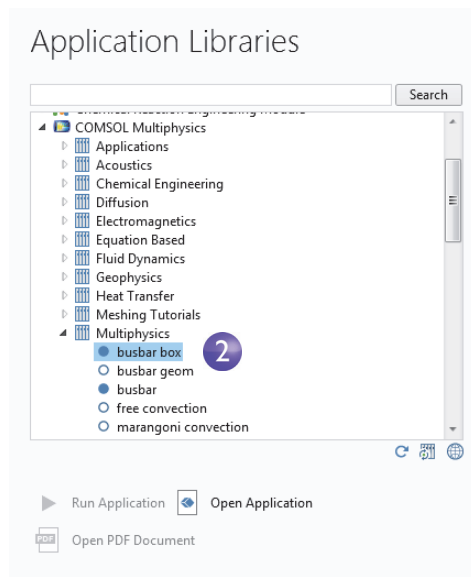

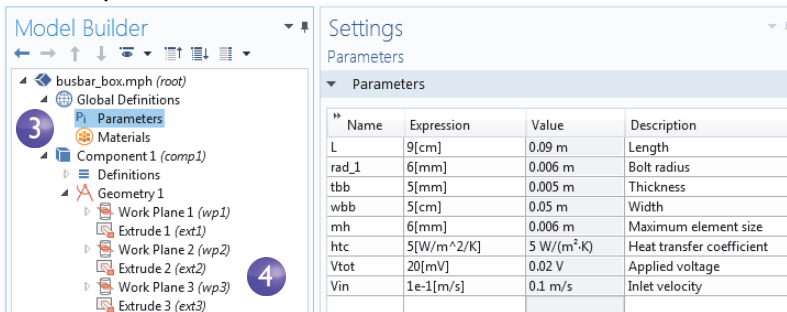

- 3 Under Global Definitions, click the Parameters node .
- 4 In the Settings window for Parameters click the empty row just below the Vtot row. In the Name column, enter Vin. Enter $1e-1$ [m/s] in the Expression column and a description of your choice in the Description column, such as Inlet velocity.





- 5 Select File>Save As and save the model with a new name, busbar_box_I.mph.

ADDING AIR

The next step is to add the material properties of air.

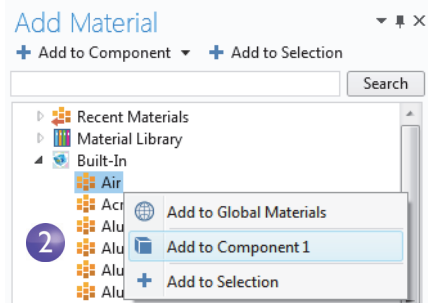
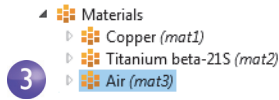
- 1 From the Home tab, select Add Material  (or right-click the Materials node and select Add Material.)
- 2 In the Add Material window, expand the Built-In node. Right-click Air and select Add to Component 1. Close the Add Material window.
- 3 In the Model Builder under Materials, click the Air node .



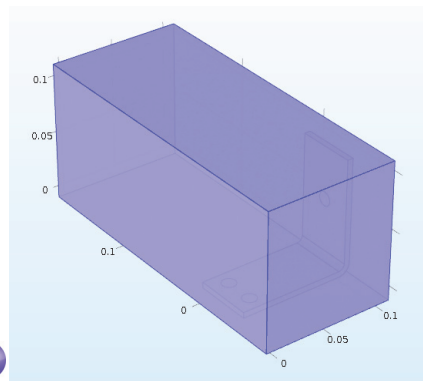
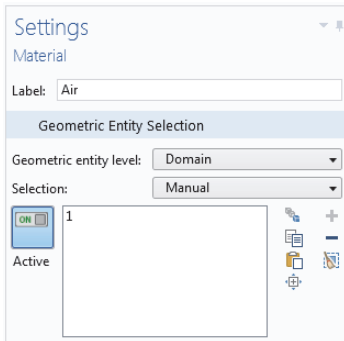

- 4 On the Graphics window toolbar, click Zoom Extents .
- 5 In the Graphics window, click the air box (Domain 1) to add it to the Selection list, which changes the color to blue. This step assigns the air material properties to the air box.



ADDING FLUID FLOW

Now add the physics of fluid flow.

- 1 In the model tree, right-click Component 1  and select Add Physics .

2 In the Add Physics window under Fluid Flow>Single-Phase Flow, right-click Laminar Flow and select + Add to Component. Laminar Flow will appear under Component 1 in the Model Builder. Close the Add Physics window.

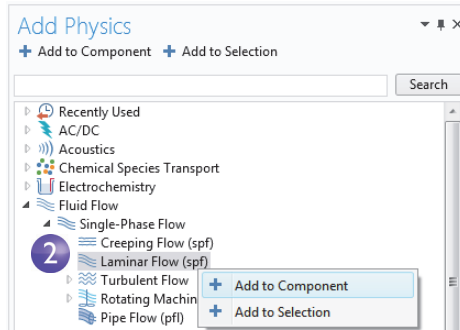

3 On the Graphics toolbar, click the Transparency button. In addition, click the Wireframe Rendering button. These two settings make it easier to see inside the box. Toggle these on and off as needed during the modeling process to control the type of rendering used.

Now that you have added fluid flow to the model, you need to remove the air domain (Domain 1) from the Electric Currents (ec) interface (we are assuming that the air has no electric conductivity and hence no currents) and then couple the heat transfer part of the Joule heating multiphysics interface to the fluid flow.

4 In the Model Builder, select the Electric Currents (ec) node. In the Graphics window, move the mouse pointer over the air domain and click to remove it from the selection list. At this point, only the busbar should be selected and highlighted in blue.

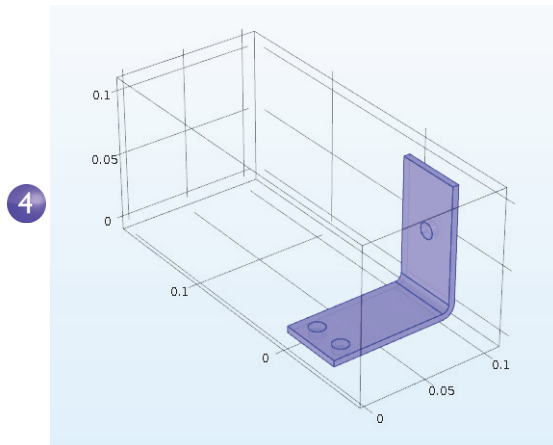

- 5 In the Model Builder, right-click Heat Transfer in Solids . In the first section of the context menu, the domain level , select Heat Transfer in Fluids.

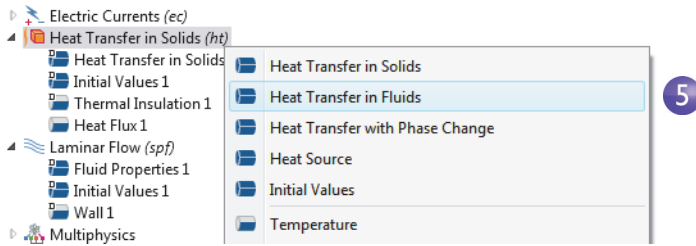

- 6 In the Graphics window, click the air domain (Domain 1) to add it to the Selection list.

Now couple the fluid flow and the heat transfer phenomena.

6

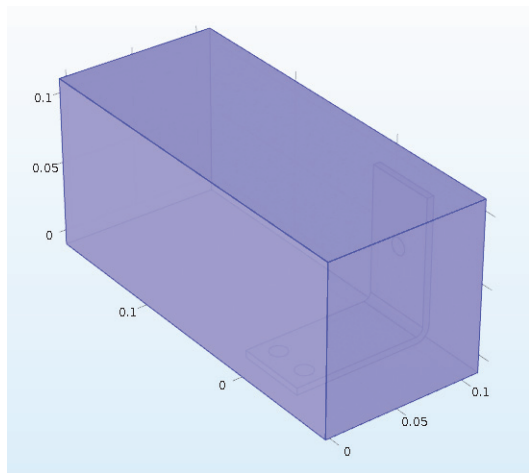

- 7 In the Settings window for Heat Transfer in Fluids under Model Inputs, select Velocity field (spf) from the Velocity field list. Then, select Absolute pressure (spf) from the Absolute pressure list.



This identifies the flow field and pressure from the Laminar Flow interface and couples it to heat transfer.

7

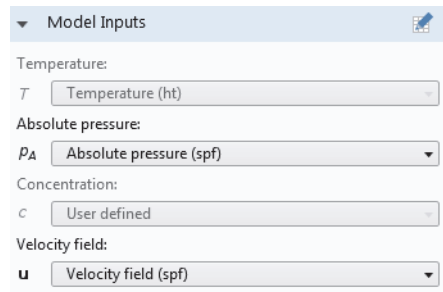
7



Now define the boundary conditions by specifying the inlet and outlet for the heat transfer in the fluid domain.

- 8 In the Model Builder, right-click Heat Transfer in Solids . In the second section of the context menu, the boundary section , select Temperature.

A Temperature node is added to the Model Builder.

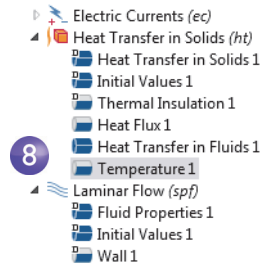

- 9 In the Graphics window, click the inlet boundary, Boundary 2, to add it to the Selection list.

This sets the inlet temperature to 293.15 K, the default setting.

The graphics should look like the image to the right (it may look slightly different depending on whether you have Transparency and Wireframe Rendering on or off.) Continue by defining the outlet.

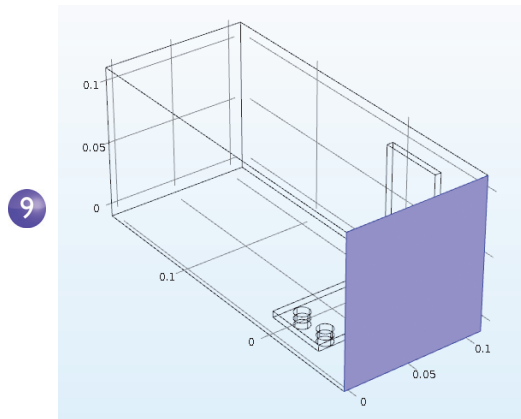

- 10 In the Model Builder, right-click Heat Transfer in Solids . At the boundary level, select Outflow. An Outflow node  is added to the Model Builder.

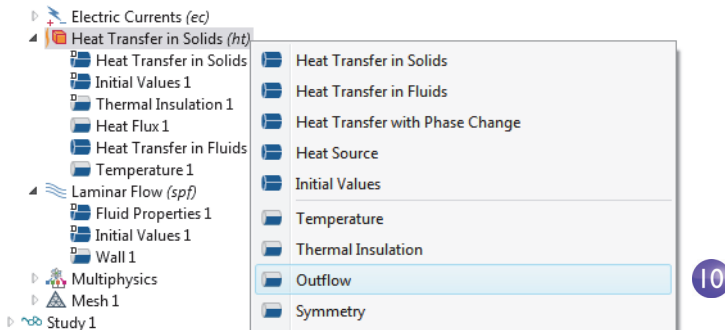

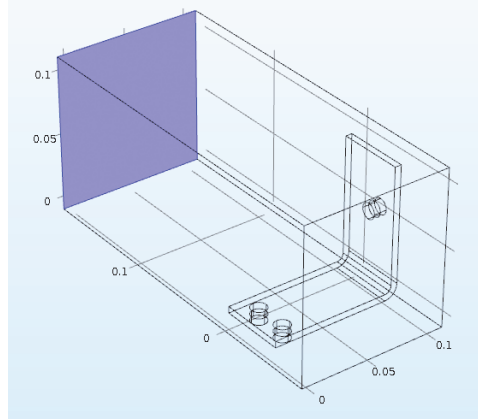

|| In the Graphics window, click the outlet boundary, Boundary 5, to add it to the Selection list. Use the mouse scroll wheel to scroll in and highlight the boundary before selecting it, or use the up and down arrow keyboard buttons.

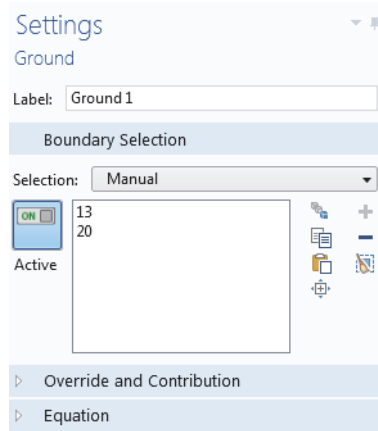
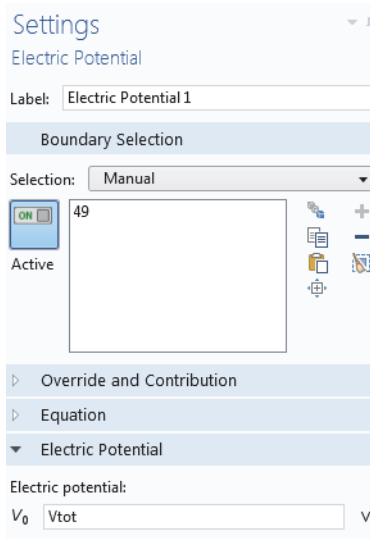

! The settings for the busbar, the bolts, and the Electric Potential 1 and Ground 1 boundaries have retained the correct selection, even though you added the box geometry for the air domain. To confirm this, in the Model Builder under Electric Currents, click the Electric Potential 1 and the Ground 1 nodes to verify that they have the correct boundary selection.



Let's continue with the flow settings. You need to indicate that fluid flow only takes place in the fluid domain and then set the inlet, outlet, and symmetry conditions.

- In the model tree, click the Laminar Flow node . In the Settings window for Laminar Flow click the Clear Selection button .

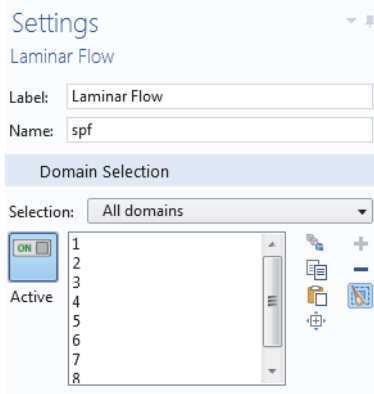



- In the Graphics window, click the air box (Domain 1) to add it to the Selection.

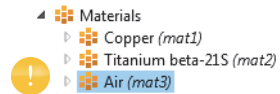

It is good practice to verify that the Air material under the Materials node has all the properties that this multiphysics combination requires. In the model tree under Materials, click Air. In the Settings window for Material under Material Contents, verify that there are no missing properties, which are marked with a warning sign . The section “Materials” on page 61 has more information.



Let's continue with the boundaries.

- In the Model Builder, right-click Laminar Flow  and at the boundary level select Inlet. An Inlet node  is added to the Model Builder.

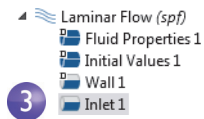

- 4 In the Graphics window, click the inlet (Boundary 2) to add it to the Selection list.

4

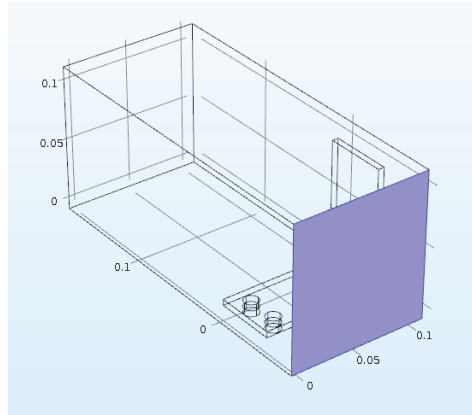

- 5 In the Settings window for Inlet under Velocity in the U_0 field, enter V_{in} to set the Normal inflow velocity.

5



- 6 Right-click Laminar Flow \approx and at the boundary level select Outlet \square . In the Graphics window, click the outlet (Boundary 5) to add it to the Selection list. Use the mouse scroll wheel or keyboard arrows to scroll in and highlight the boundary before selecting it.

6

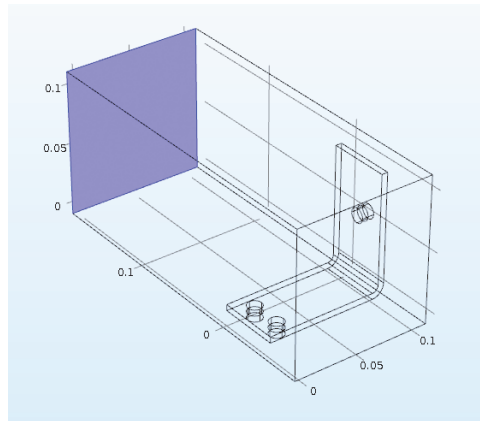

The last step is to add symmetry boundaries. You can assume that the flow just outside of the faces of the channel is similar to the flow just inside these faces. This assumption can be correctly expressed by the symmetry condition.

- 7 Right-click Laminar Flow \approx and select Symmetry. A Symmetry node \square is added to the sequence.

- 8 In the Graphics window, click each of the blue faces in the figure below (Boundaries 1, 3, 4, and 48) to add all of them to the Selection list. You may

need to use the mouse scroll wheel or rotate the geometry to select all of them.

Save the `busbar_box_I.mph` file, which now includes the Air material and Laminar Flow interface settings.

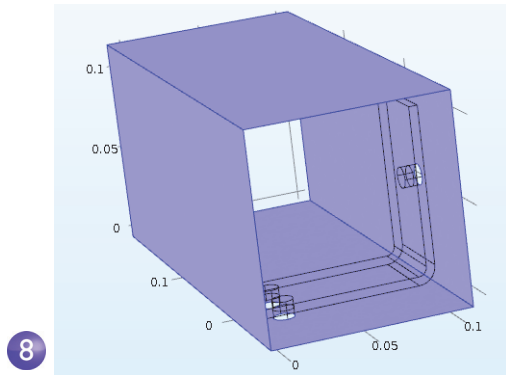

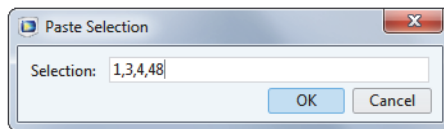

When you know the boundaries, you can click the Paste Selection button  and enter the information. In this example, enter 1, 3, 4, 48 in the Paste Selection window.



Click OK and the boundaries are automatically added to the Selection list.

COARSENING THE MESH

To get a quick solution, we will change the mesh slightly and make it coarser. The current mesh settings would take a relatively long time to solve, and you can always refine it later.

In the Model Builder, expand the Mesh 1 node  and click the Size node .



- 2 In the Settings window for Size under Element Size, click the Predefined button and ensure that Normal is selected.

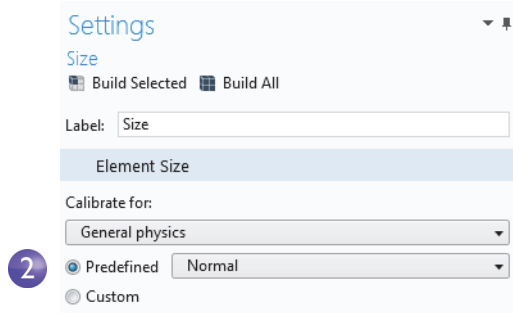

- 3 Click the Build All button . The geometry displays with a mesh in the Graphics window (you may need to turn Transparency off to see the picture below.)

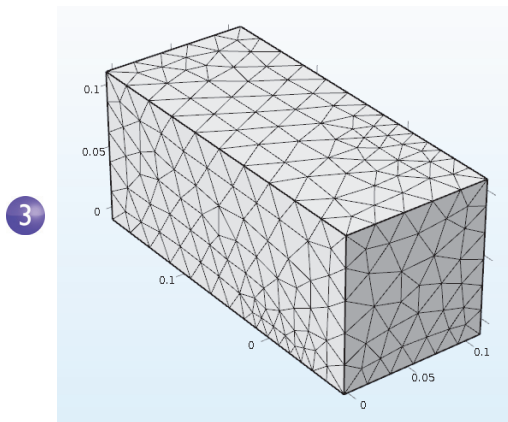

You can assume that the flow velocity is large enough to neglect the influence of the temperature increase in the flow field.

It follows that you can solve for the flow field first and then solve for the temperature using the results from the flow field as input. This is implemented with a study sequence.

SOLVING FOR FLUID FLOW AND JOULE HEATING

When the flow field is solved before the temperature field it yields a weakly coupled multiphysics problem. The study sequence described in this section automatically solves such a weak coupling.

- In the model tree, right-click Study 1 and select Study Steps>Stationary>Stationary to add a second stationary study step to the Model Builder.

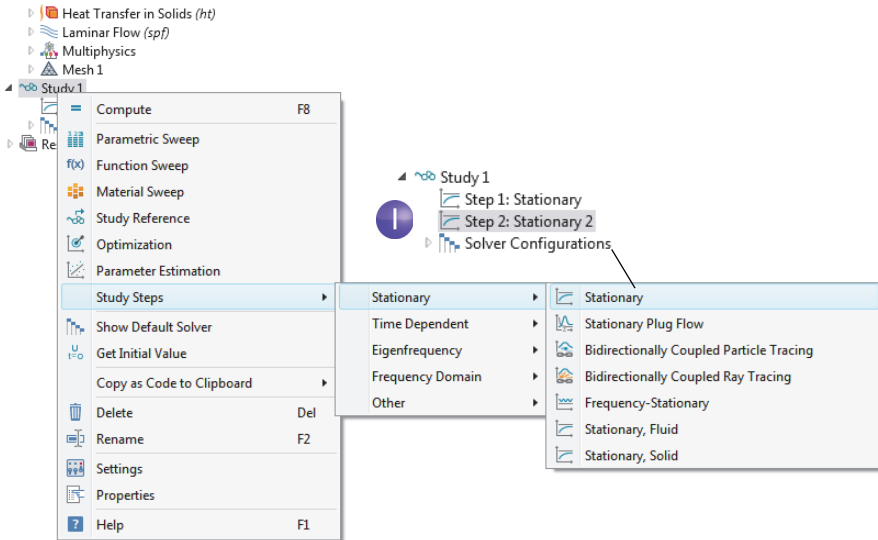

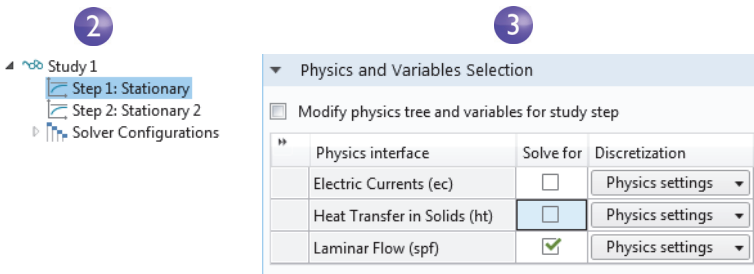

Next, the correct physics needs to be connected with the correct study step. Start by disabling the Electric Currents (ec) and Heat Transfer in Solids (ht) interfaces associated with Joule heating from the first step.

- Under Study 1, click Step 1: Stationary.



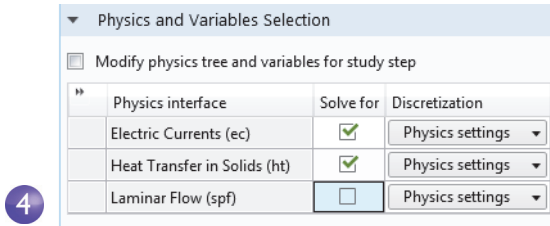

- In the Settings window for Stationary locate the Physics and Variables Selection section. In both the Electric Currents (ec) and the Heat Transfer in Solids (ht) rows, click to change the check mark to an , removing Joule heating from Step 1.

- 4 Repeat the step. Under Study 1, click Step 2: Stationary 2 . Under Physics and Variables Selection, in the Laminar Flow (spf) row, click in the Solve for column to change the check mark  to an .

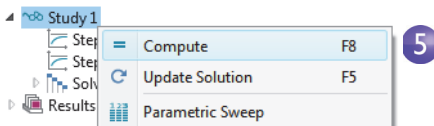

- 5 Right-click the Study 1 node  and select Compute = (or press F8 or click Compute in the ribbon). This will now automatically create a new solver sequence that solves for laminar flow and then Joule heating.



- 6 After the solution is complete, select the Temperature (ht) plot under the Results node in the Model Builder. If you don't already have transparency on, click the Transparency button  on the Graphics toolbar to visualize the

temperature field inside the box. To zoom, middle-click and hold down the mouse button (or scroll wheel) while dragging the mouse.

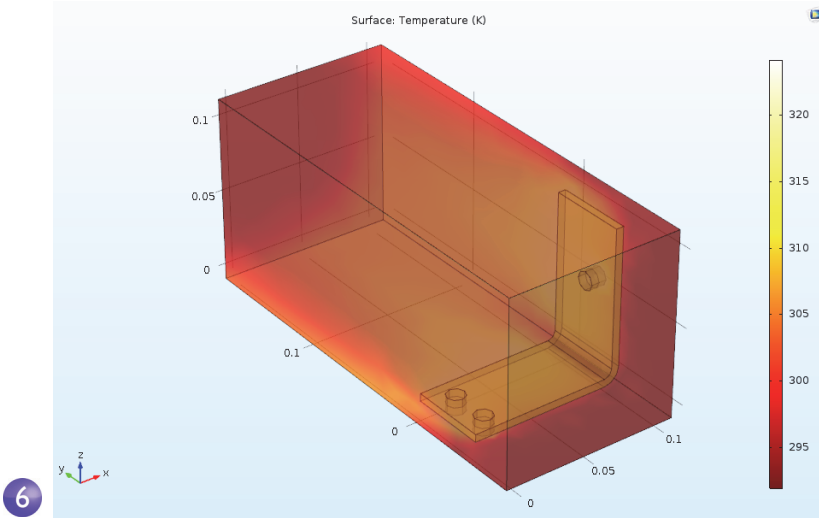

The Temperature Surface plot that displays in the Graphics window shows the temperature in the busbar and in the surrounding box. You can also see that the temperature field is not smooth due to the relatively coarse mesh. A good strategy to get a smoother solution would be to refine the mesh to estimate the accuracy.

- 7 Save the `busbar_box_I.mph` file at this point so you can return to this file if you want. The next steps use the original `busbar.mph` file.

Parametric Sweeps

SWEEPING A GEOMETRIC PARAMETER

It is often useful to generate multiple instances of a design with the objective of meeting specific constraints. In the previous busbar example, a design goal might be to lower the operating temperature, or to decrease the current density. We will demonstrate the former. Since the current density depends on the geometry of the busbar, varying the width, w_{bb} , should change the current density and, in turn, have some impact on the operating temperature. Let us run a parametric sweep on w_{bb} to study this change.

ADDING A PARAMETRIC SWEEP

- 1 From the File menu, open the model file `busbar.mph`. If you didn't save the model, you can also open it from the Application Libraries: File menu > Application Libraries > COMSOL Multiphysics > Multiphysics > `busbar`. In the Model Builder, right-click Study 1 and select Parametric Sweep. A Parametric Sweep node is added to the Model Builder sequence.

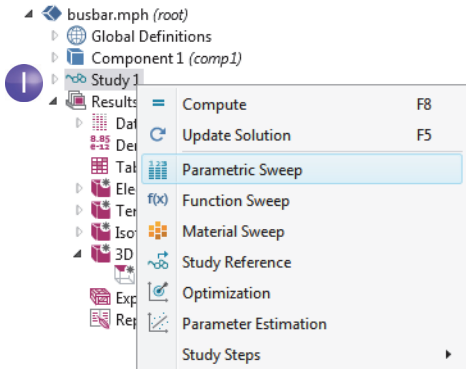

- 2 In the Settings window for Parametric Sweep, under the empty parameter table, click the Add button **+**. From the Parameter names list in the table, select `wbb`.

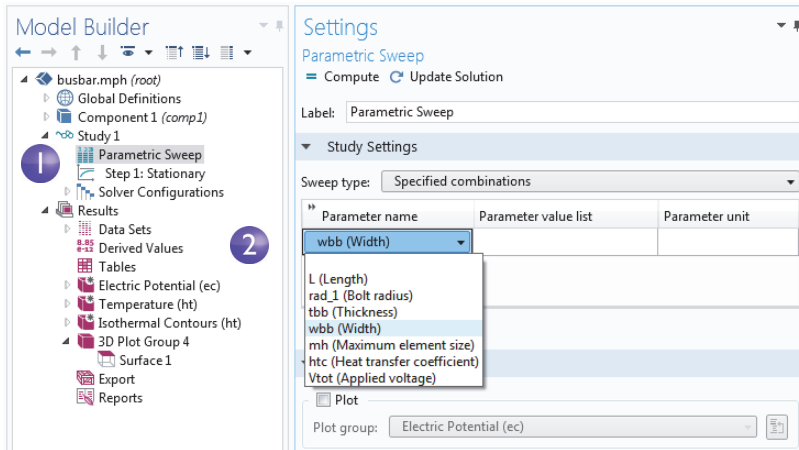

- 3 The Sweep type, available above the Parameter names, is used to control parametric sweeps with multiple parameters. You select between sweeping for All combinations of the given parameters or a subset of Specified combinations.

3 Enter a range of parameter values to sweep the width of the busbar from 5 cm to 10 cm in 1 cm increments. There are different ways to enter this information:

- Copy and paste or enter range (0.05,0.01,0.1) into the Parameter value list field.
- Click the Range  button and enter the values in the Range dialog box. In the Start field, enter 5e-2. In the Step field, enter 1e-2, and in the Stop field, enter 1e-1. Click Replace.
- In any of the methods, you can also use length units to override the default SI unit system using meters. Instead of 5e-2 you can enter 5[cm], similarly 1[cm] instead of 1e-2 and 10[cm] instead of 1e-1. You can also change the default unit system from the Settings window of the root node in the model tree.

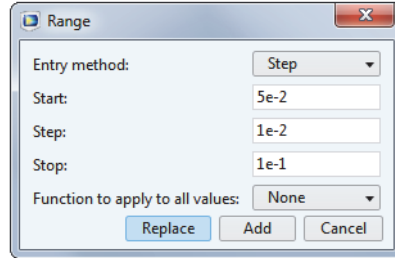

3

Next, define an Average component coupling that can be used later to calculate the average temperature in the busbar.

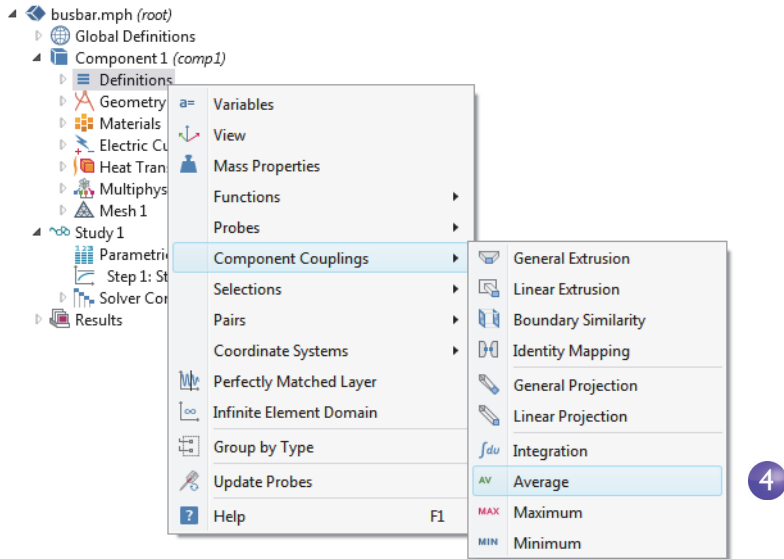

- 4 Under Component 1, right-click Definitions  and select Component Couplings>Average  .

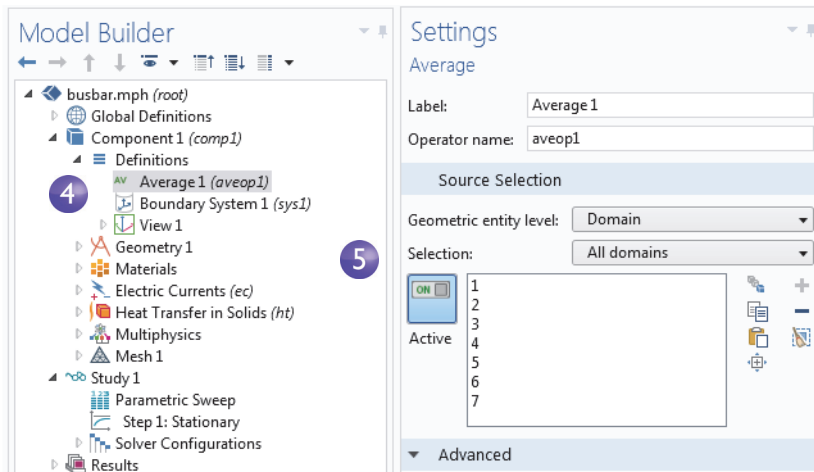

- 5 In the Settings window for Average select All domains from the Selection list.



This creates an operator called `aveop1`. This operator is now available to calculate the average of any quantity defined on the selected domains. A little later this is used to calculate the average temperature, but it can also be used to calculate average electric potential, current density, and so forth.

- 6 Select File>Save As to save the model with the new name, busbar_III.mph.
- 7 Right-click Study 1  and select Compute  to run the sweep or click Compute in the Home tab.

PARAMETRIC SWEEP RESULTS

Click the Temperature (ht) 1 node located under Results in the Model Builder.

The plot that displays in the Graphics window shows the temperature in the wider busbar using the last parameter value, $wbb=0.1\text{ [m]}$ (10[cm]). Select Zoom Extents  from the Graphics window toolbar so that you can see the entire plot. The resulting plot is rather uniform in color, so we need to change the maximum color range.

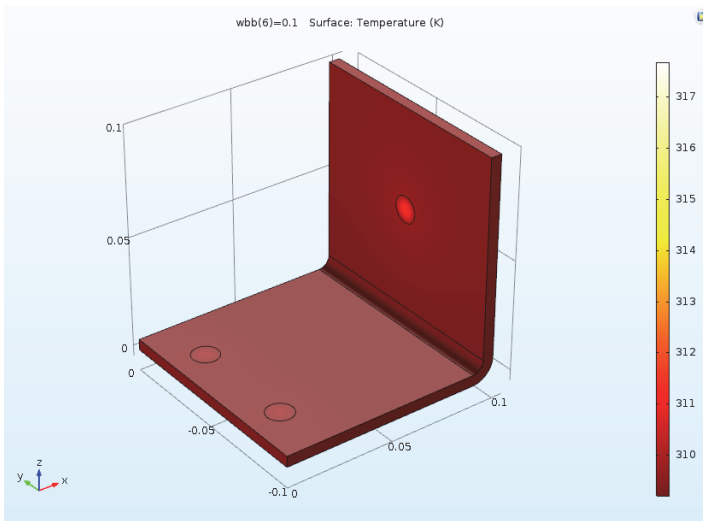
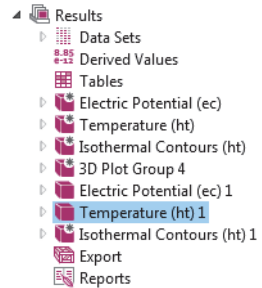

- I Under the Temperature (ht) 1 node, click the Surface node .

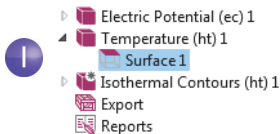

- 2 In the Settings window for Surface click Range to expand the section. Select the Manual color range check box. Enter 309.4 in the Maximum field (replace the default).
- 3 The Temperature (ht) 1 plot is updated in the Graphics window for $wbb=0.1$ [m] (10[cm]).

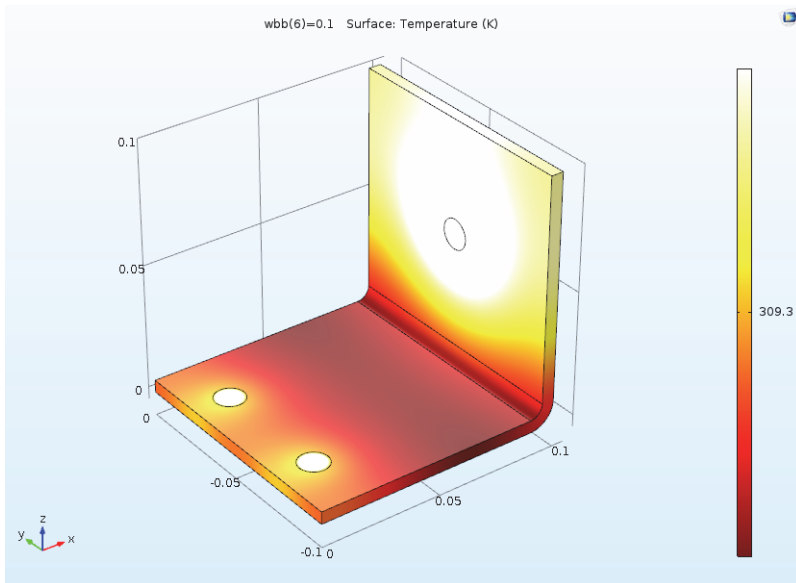
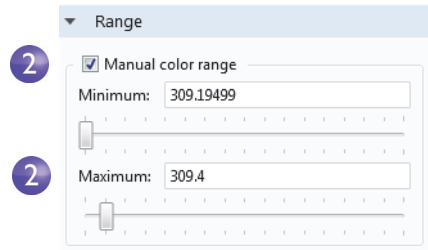

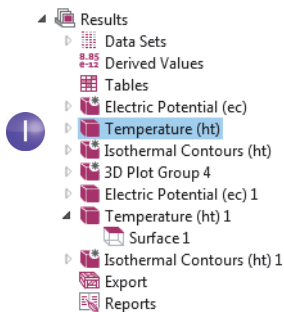

Compare the wider busbar plot to the temperature for $wbb=0.05$ [m] (5[cm]).

- 1 In the Model Builder, click the first Temperature (ht) node .

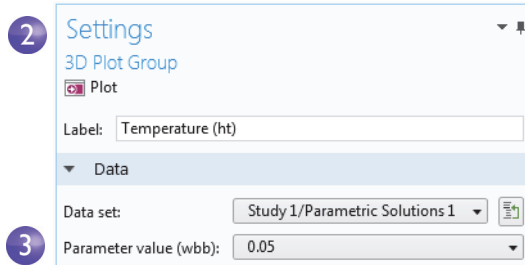

2 In the Settings window for 3D Plot Group select Study 1/Parametric Solutions 1 from the Data set list. This data set contains the results from the parametric sweep.



3 In the Parameter value list, select 0.05 (which represents $wbb=5$ cm). Click the Plot button .

Click the Zoom Extents button  on the Graphics window toolbar.

The Temperature (ht) plot is updated for $wbb=0.05$ [m] (5 [cm]). Note that if you have updated the color range for this plot already, your plot should look similar to the one below. If not, follow the subsequent steps.

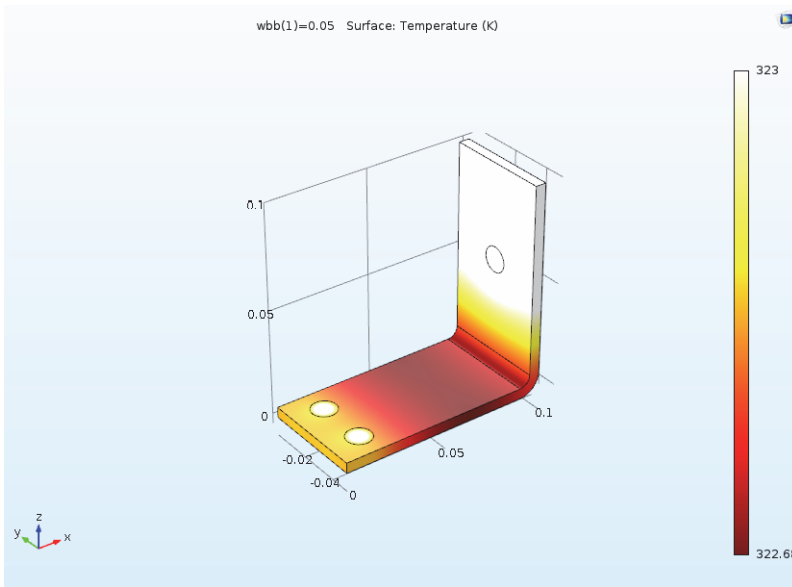

Like the wider busbar, the plot may be quite uniform in color, so change the maximum color range.

1 Under the first Temperature (ht) node, click the Surface node .

2 In the Settings window for Surface click Range to expand the section (if it is not already expanded). Select the Manual color range check box.



3 Enter 323 in the Maximum field (replace the default) to plot w_{bb} at 5 cm.

The Temperature (ht) plot is updated in the Graphics window for $w_{bb}=0.05[m]$ (5[cm]).

Click the first and second Temperature plot nodes to compare the plots in the Graphics window. The maximum temperature decreases from 331 K to 318 K as the width of the busbar increases from 5 cm to 10 cm.

ADDING MORE PLOTS

To further analyze these results, you can plot the average temperature for each width.

1 Right-click Results  and add a 1D Plot Group .

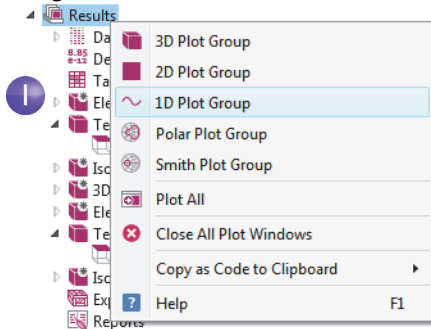

2 In the Settings window for 1D Plot Group select Study 1/Parametric Solutions 1 from the Data set list.

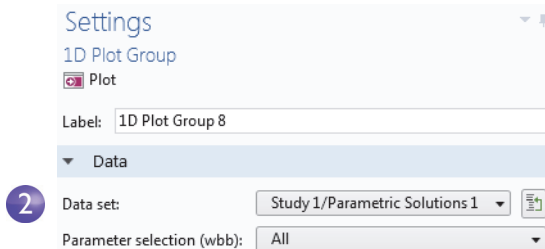

3 In the Model Builder, right-click 1D Plot Group 8 and add a Global  node.

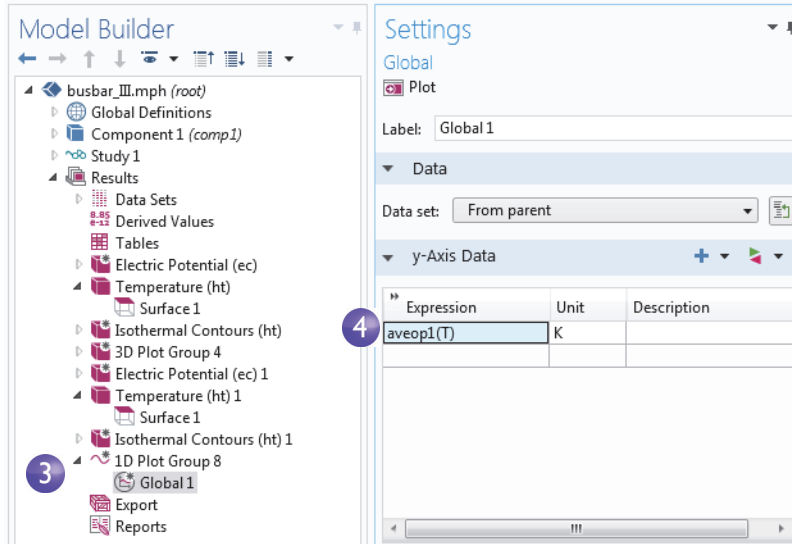

4 In the Settings window for Global under y-Axis Data, click the first row in the Expressions column and enter `aveop1(T)`. This operator is the one we defined on page 126 for later use. You use a similar syntax to calculate the average of other quantities.

 To use a coupling operator without solving, you can select the option Update Solution that is available by right-clicking a Study node.

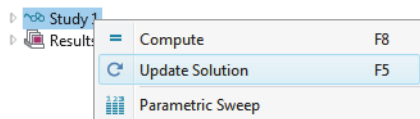

5 Click to expand the Legends section. Select the Expression check box. This adds a legend at the top right corner of the graph.

- 6 Click the Plot button  and save the busbar_III.mph model with these additional plots that use the parametric sweep results.

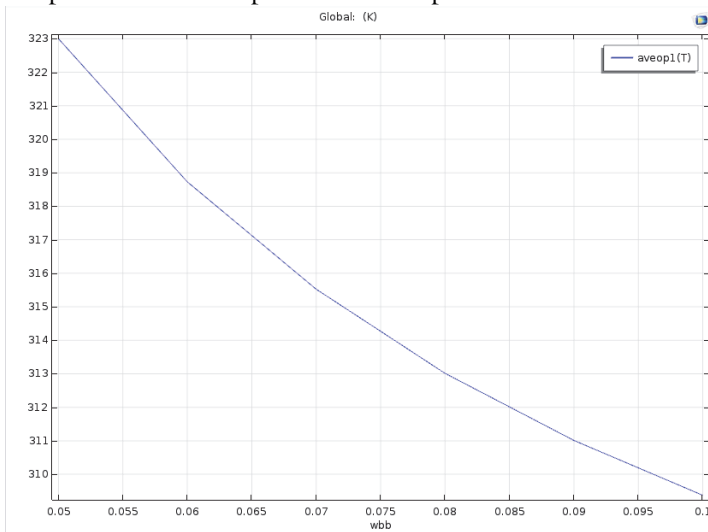

In the plot, the average temperature also decreases as the width increases. This indicates that the goal of a lower operating temperature would be fulfilled by using a wider busbar.

The subject of parametric sweeps raises the question of parallel computing; it would be efficient if all parameters were solved simultaneously.

Parallel Computing

COMSOL supports most forms of parallel computing including shared memory parallelism for multicore processors and high performance computing (HPC) for clusters and clouds. All COMSOL licenses are multicore enabled. For cluster or cloud computing, including parallelized sweeps, a Floating Network License is needed.

You can use clusters or clouds either for Cluster Sweep or for Cluster Computing. If you have a Floating Network License, these two options are available by right-clicking the Study node. However, you first need to enable Advanced Study

Options by clicking the Show button  on the Model Builder toolbar and selecting Advanced Study Options.

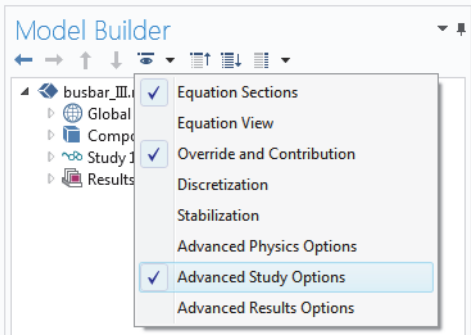

CLUSTER SWEEP

Cluster Sweep is used for solving several models in parallel where each model has a different set of Parameters. This can be seen as a generalization of Parametric Sweep. Right-click the Study 1 node to add a Cluster Sweep node.

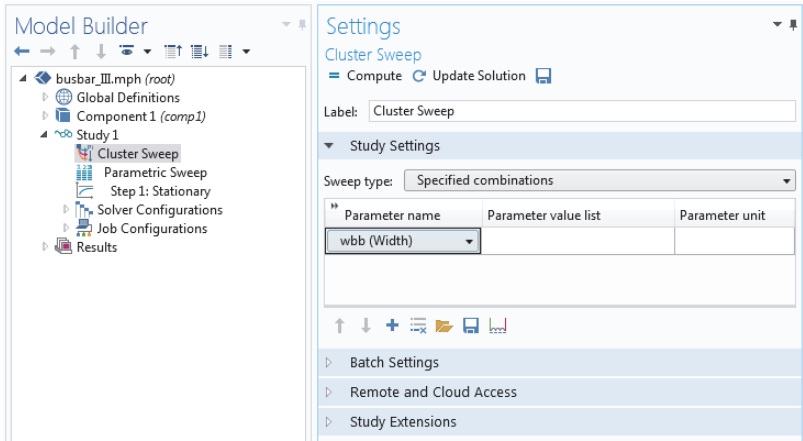

The Study Settings for Cluster Sweep are similar to that of Parametric Sweep, but additional settings are required for the cluster or cloud being used. The picture above shows how the top of the Settings window for Cluster Sweep would look for the same sweep as defined in “Parametric Sweeps” on page 123.

CLUSTER COMPUTING

You can also utilize a cluster or cloud to solve a single large model using distributed memory. For maximum performance, the COMSOL cluster implementation can utilize shared-memory multicore processing on each node in combination with the Message Passing Interface (MPI) based distributed memory model. This is also known as hybrid parallelism and brings a major performance boost by making the most out of the computational power available.

Right-click the Study node to add a Cluster Computing node. A Cluster Computing node cannot be used in combination with a Cluster Sweep. You will be asked if you want to remove the Cluster Sweep before proceeding, select Yes.

The Settings window for Cluster Computing, shown below, helps to manage the simulation with settings for the cluster or cloud.

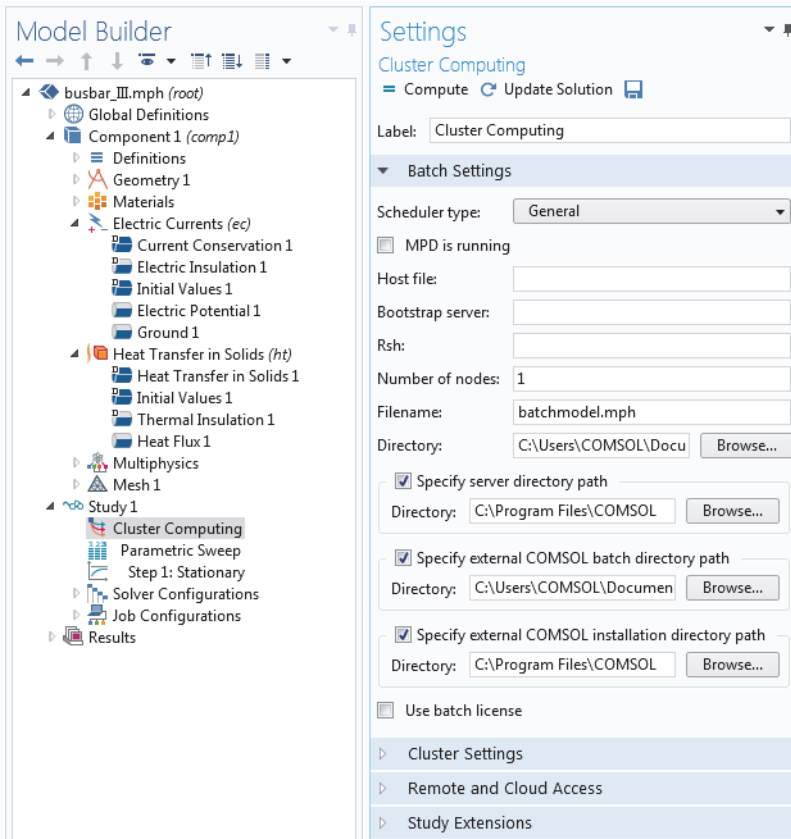

You choose the type of cluster job you want to perform from the Cluster type list. COMSOL supports Windows[®] Compute Cluster Server (WCCS) 2003, Windows[®] HPC Server (HPCS) 2008, Open Grid Scheduler/ Grid Engine (OGS/GE), SLURM, or Not distributed.



To learn more about running COMSOL in parallel, see the *COMSOL Multiphysics Reference Manual*.

Appendix A—Building a Geometry

This section details how to create the busbar geometry using the built-in geometry tools in COMSOL. The step-by-step instructions take you through the construction of the geometry using the parameters set up in the Global Definitions section. Using parameterized dimensions helps to produce *what-if* analyses and geometric parametric sweeps.



As an alternative to building the geometry in COMSOL, you can import a geometry from a CAD package. The optional CAD Import Module supports many CAD file formats. Moreover, several add-on products are available that provide bidirectional interfaces to common CAD software packages. See “Appendix E—Connecting with LiveLink™ Add-Ons” on page 174 for a list.

If you have not done so already, start with “Example 2: The Busbar—A Multiphysics Model” on page 53. Follow the steps under the Model Wizard to add the physics and study and then follow the steps under Global Definitions to add the parameters. Return to this section to learn about geometry modeling. The first step in the geometry sequence is to draw the profile of the busbar.

- Under Component 1, right-click Geometry 1  and select Work Plane . In the Settings window for Work Plane:
 - Select xz-plane from the Plane list.
 - Click the Show Work Plane button  on the Settings window for Work Plane toolbar.

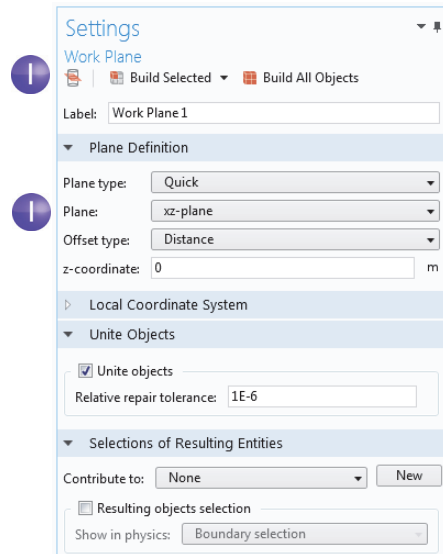
Continue by editing the axis and grid settings in Work Plane 1.



2 In the Model Builder, expand the View 2 node  and click Axis .

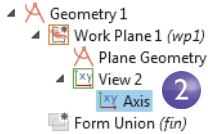

3 In the Settings window for Axis:

Under Axis:

- In the x minimum and y minimum fields, enter -0.01.
- In the x maximum and y maximum fields, enter 0.11.

Under Grid:

- Select the Manual Spacing check box.
- In the x spacing and y spacing fields, enter $5e-3$.

4 Click the Update button  on the toolbar.

Note that the values you type will automatically adjust slightly after you click Update to adapt to the screen aspect ratio.

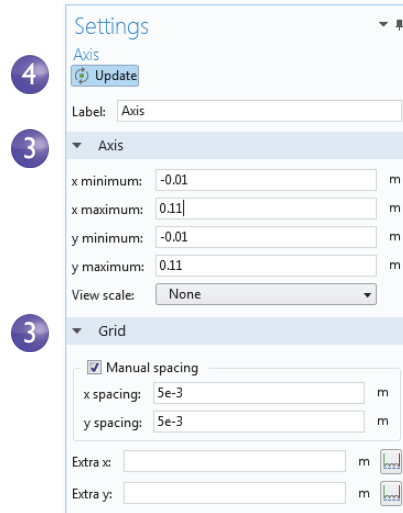

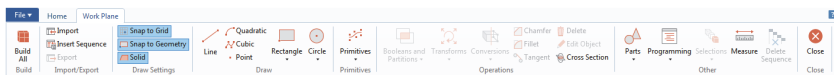

You can use interactive drawing to create a geometry using the drawing tools from the Work Plane tab in the ribbon while pointing and clicking in the Graphics window.

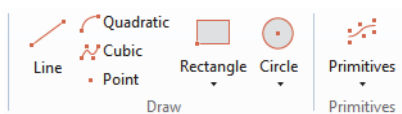

Work Plane Tab



Geometry Primitives

You can also right-click the Plane Geometry node  under Work Plane 1  to add geometry objects to the geometry sequence.

In the next few steps we create a profile of the busbar.

- 5 In the Model Builder under Work Plane 1, right-click Plane Geometry  and select Rectangle .

In the Settings window for Rectangle under Size, enter:

- $L+2*tbb$ in the Width field.
- $0.1 [m]$ in the Height field.

Click the Build Selected button .

5

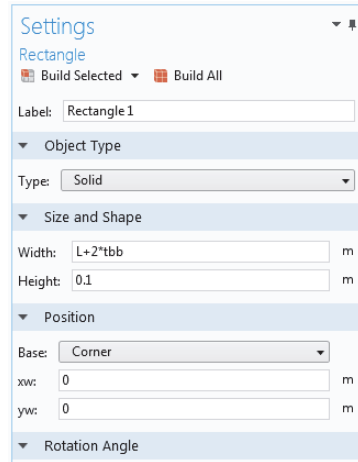

Settings
Rectangle
Build Selected Build All
Label: Rectangle 1
Object Type
Type: Solid
Size and Shape
Width: $L+2*tbb$ m
Height: 0.1 m
Position
Base: Corner
xw: 0 m
yw: 0 m
Rotation Angle

- 6 Create a second rectangle. Under Work Plane 1, right-click Plane Geometry  and select Rectangle .

Under Size, enter:



- $L+tbb$ in the Width field
- $0.1 [m] - tbb$ in the Height field.

Under Position, enter:

- tbb in the yw field.

Click the Build Selected button .

Use the Boolean Difference operation to subtract the second rectangle from the first one.

- 7 Under Work Plane 1, right-click Plane Geometry  and select Booleans and Partitions > Difference . In the Graphics window, click r1 (the larger of the

6

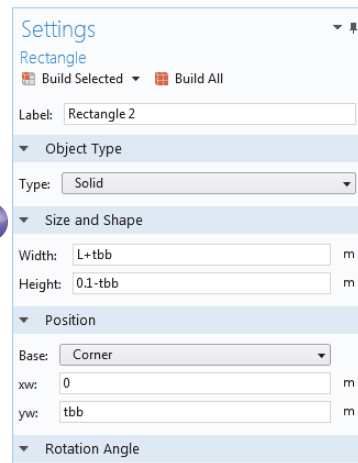

Settings
Rectangle
Build Selected Build All
Label: Rectangle 2
Object Type
Type: Solid
Size and Shape
Width: $L+tbb$ m
Height: $0.1-tbb$ m
Position
Base: Corner
xw: 0 m
yw: tbb m
Rotation Angle

two rectangles) to add it to the Objects to add list in the Settings window for Difference.

- ! To help select the geometry you can display geometry labels in the Graphics window. In the Model Builder under Geometry 1>WorkPlane 1, click the View 2 node. Go to the Settings window for View and select the Show geometry labels check box.

- 8 Click the Difference node. In the Settings window for Difference, click the Active selection button to the left of the Objects to subtract list. Select the smaller rectangle, r2, by using the mouse scroll wheel or arrow keys to cycle through the overlapping rectangles to first highlight it, and then click on it to select it.

Click Build Selected .

Another way to select r2 in the Graphics window is to use the Selection List feature. Go to the Home tab in the ribbon and select Windows > Selection List. In the Selection List click to highlight r2 (solid). Then, right-click r2

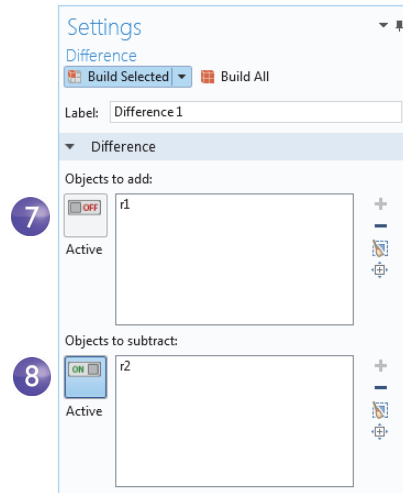

(solid) in the list and select Add to Selection to add it to the Objects to subtract list. Right-click on the Selection List window title and select Close.

After building the selected geometry, you should have a backward-facing, L-shaped profile. Continue by rounding the corners of the L-shaped profile.

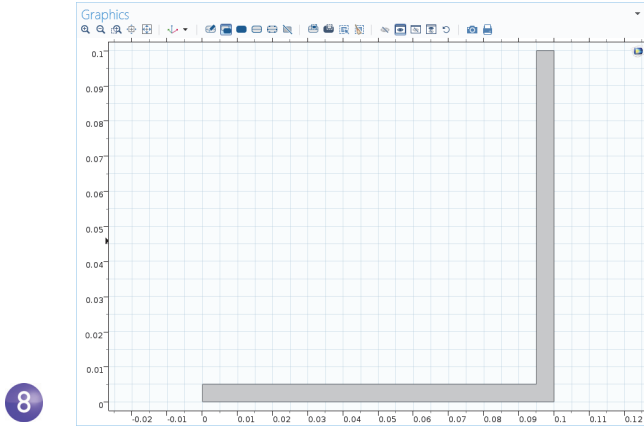



- 9 Under Work Plane 1, right-click Plane Geometry  and select Fillet .

Select point 3 to add it to the Vertices to fillet list. There are different ways to add points:

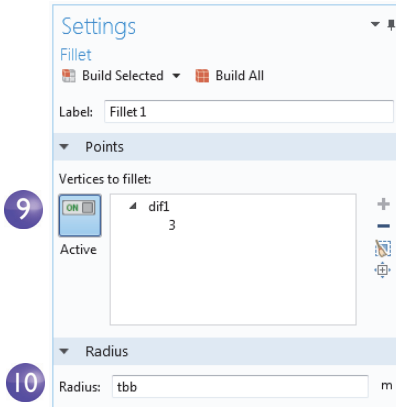

- In the Graphics window, click point 3 (in the inner right corner) to add it to the Vertices to fillet list.
- From the Home tab, select Windows > Selection List. In the Selection List window, click 3. The corresponding point is highlighted in the Graphics

window. Click the Add to Selection button **+** in the Settings window for Fillet or right-click in the Selection List.



10 Enter **tbb** in the Radius field. Click Build Selected .

This takes care of the inner corner.

11 For the outer corner, right-click Plane Geometry  and select Fillet .

12 In the Graphics window, click point **6**, the outer corner, to add it to the Vertices to fillet list.

13 Enter **2*tbb** in the Radius field. Click Build Selected .

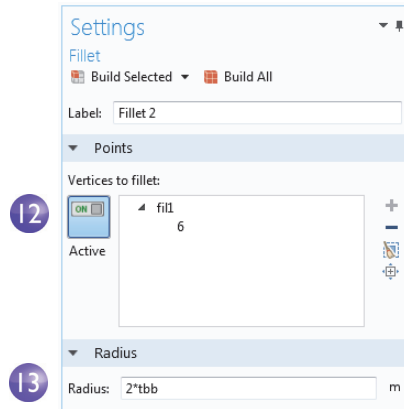

The result should match this figure:

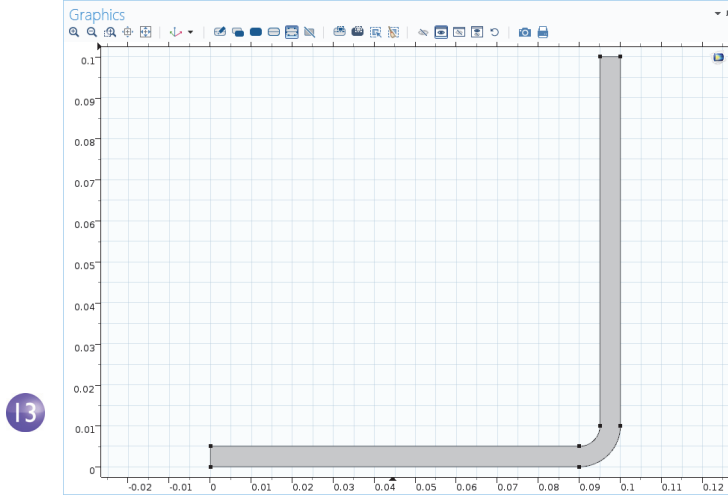

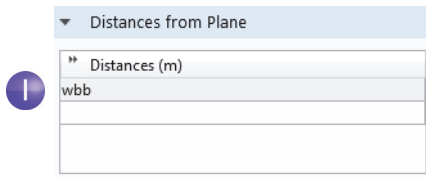

Next you extrude the work plane to create the 3D busbar geometry.

- 1 In the Model Builder, right-click Work Plane 1 and select Extrude. In the Settings window for Extrude enter `wbb` in the Distances from Plane table (replace the default) to extrude to the width of the profile.



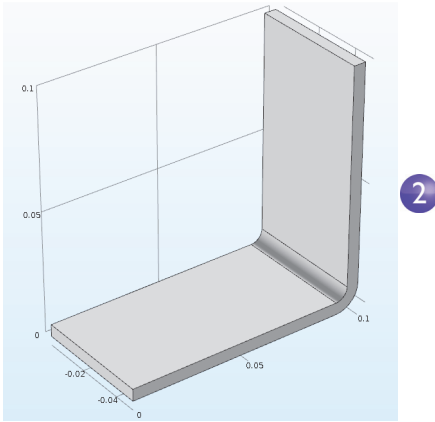

The table allows you to enter several values in order to create sandwich structures with different materials. In this case, only one extruded layer is needed.

- 2 Click Build Selected  and then click the Zoom Extents  button on the Graphics toolbar. Click the Save button  and name the model busbar .mph (if you have not already done so).



Next, create the titanium bolts by extruding two circles drawn in two work planes.

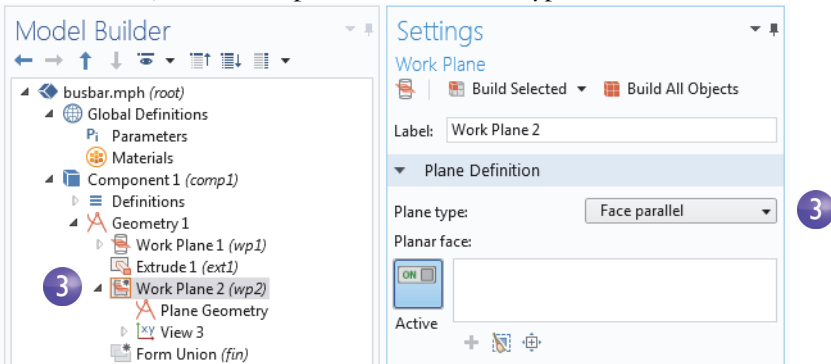

- 3 In the Model Builder, right-click Geometry 1  and add a Work Plane . A Work Plane 2 node is added. In the Settings window for Work Plane, under Plane Definition, select Face parallel as the Plane type.



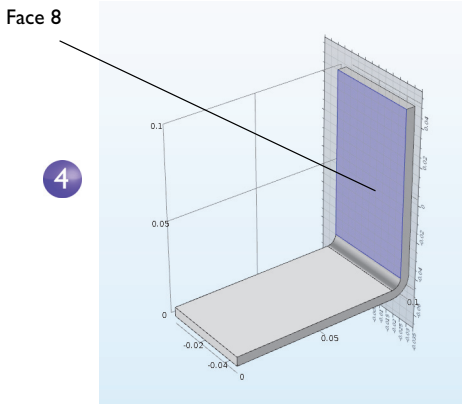

- 4 In the Graphics window, click face 8 as shown in the figure below, to add it to the Planar face list in the Settings window for Work Plane.

Face number 8 is now highlighted in blue and the work plane is positioned on top of the face.



- 5 Click the Show Work Plane button  to draw the first circle representing the position of the first bolt. Click the Zoom Extents button  on the Graphics toolbar.

- 6 Under Work Plane 2, right-click Plane Geometry  and select Circle .

In the Settings window for Circle:

- Under Size and Shape, in the Radius field, enter `rad_1`.
- Under Position, the default `xw` and `yw` coordinates (0, 0) are good.

Click Build Selected .

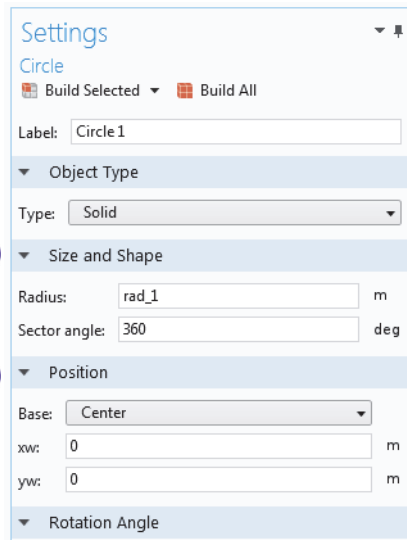

Continue creating the bolt by adding an extrude operation.

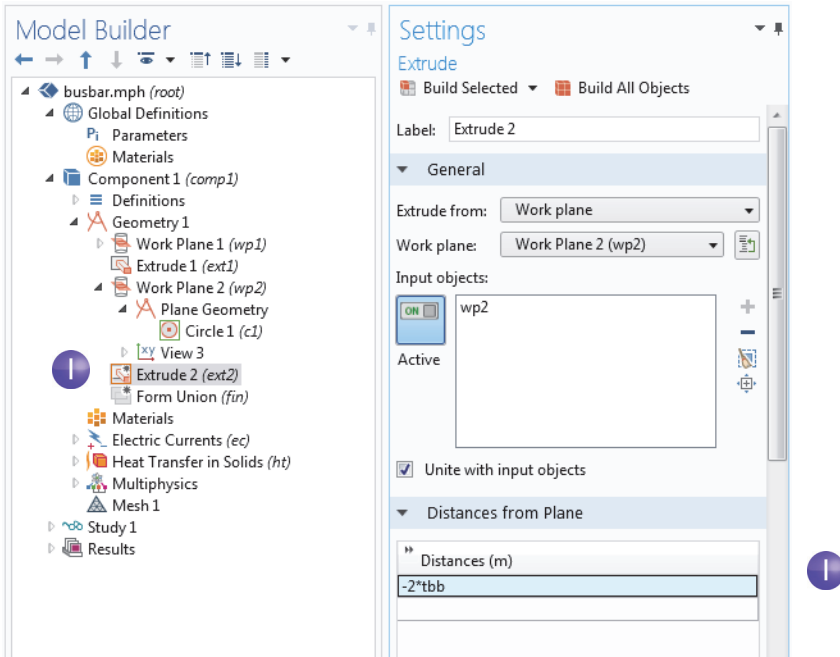

- 1 In the Model Builder, right-click Work Plane 2 and select Extrude. In the Settings window for Extrude, in the first row of the Distances from Plane table, enter $-2*t_{bb}$ to extrude the circle.



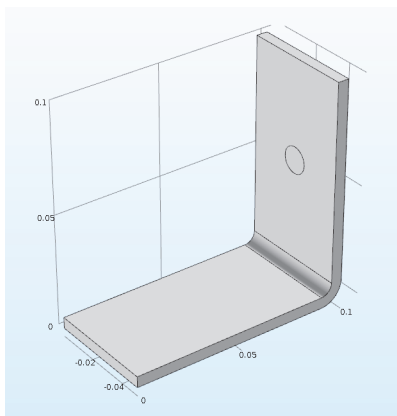

- 2 Click the Build Selected button to create the cylindrical part of the titanium bolt that runs through the busbar.

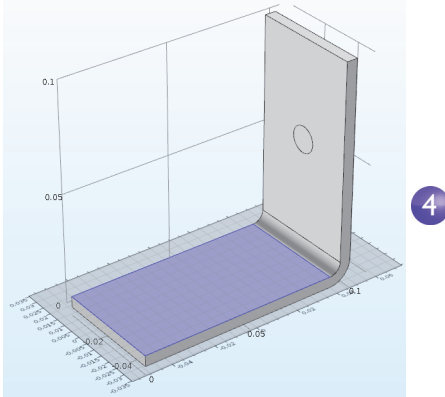

Draw the two remaining bolts.

- 3 Right-click Geometry 1  and select Work Plane . A Work Plane 3 node is added. In the Settings window for Work Plane, for Work Plane 3, select Face parallel as the Plane type.
- 4 In the Graphics window, click Face 4  as shown in the figure, to add it to the Planar face list in the Settings window for Work Plane.



- 5 Click the Show Work Plane button  on the Settings window for Work Plane and the Zoom Extents button  on the Graphics toolbar to get a better view of the geometry.

To parameterize the position of the two remaining bolts, add the circles that form the cross sections of the bolts.



- 6 Under Work Plane 3, right-click Plane Geometry  and select Circle .

In the Settings window for Circle:

- Under Size and Shape, enter rad_1 in the Radius field.
- Under Position, enter $-L/2+1.5$ [cm] in the xw field and $-wbb/4$ in the yw field.

Click Build Selected .

Copy the circle that you just created to generate the third bolt in the busbar.

- 7 Under Work Plane 3, right-click Plane Geometry  and select Transforms>Copy .

- 8 In the Graphics window, click the circle **c1** to select and add the circle to the Input objects list in the Settings window for Copy.

- 9 In the Settings window for Copy under Displacement, enter $wbb/2$ in the yw field.

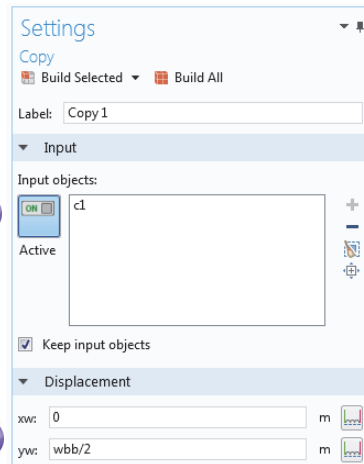
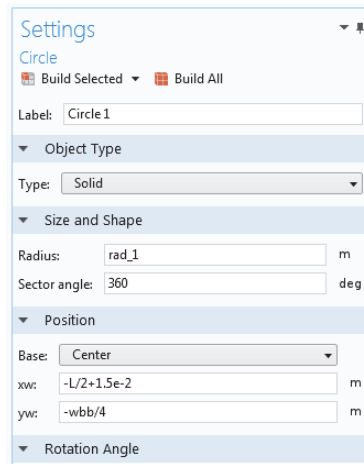

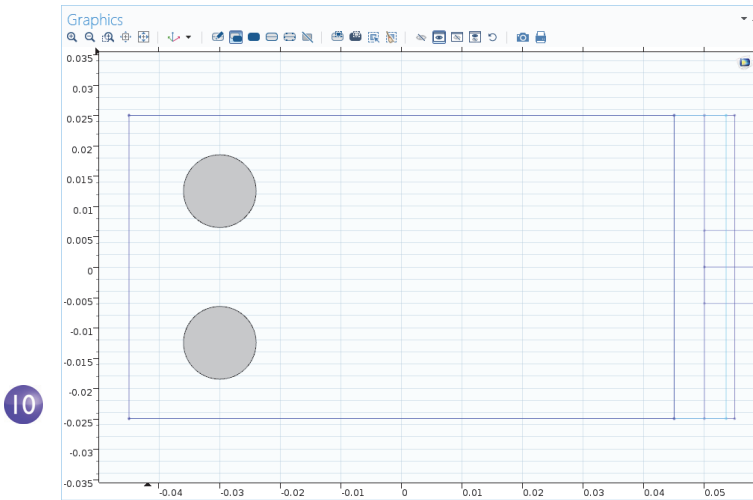

10 Click Build Selected  and click the Zoom Extents button  on the Graphics toolbar.

Your geometry, as shown in the work plane, should match this figure so far.



Continue by extruding the circles.

- || In the Model Builder, right-click Work Plane 3  and select Extrude . In the Settings window for Extrude, in the first row of the Distances from Plane table, enter $-2*tbb$ (replace the default). Click Build All Objects .

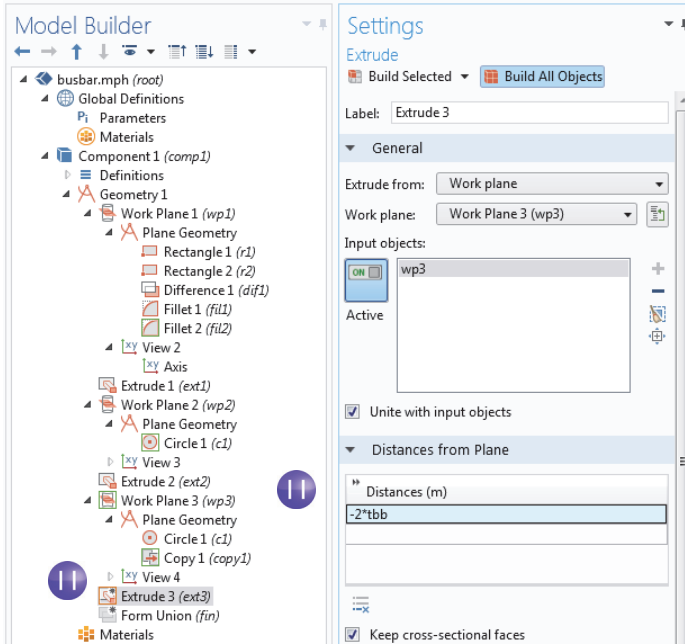

The geometry and geometry sequence should match the figures below. Click the Save button  and name the model busbar .mph.

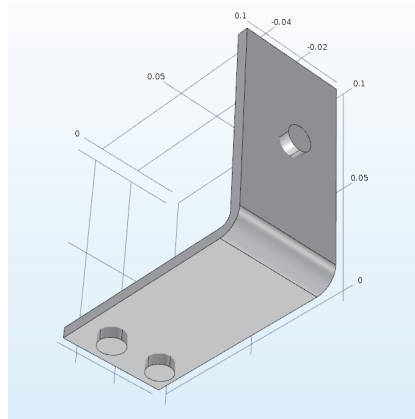
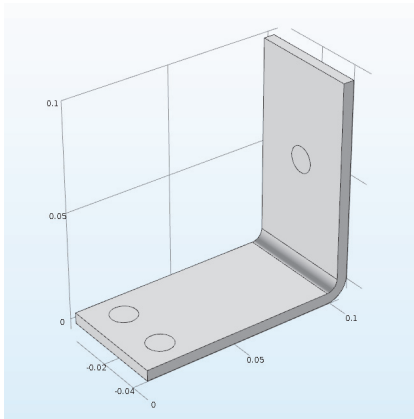

CREATING PARTS AND USING THE PART LIBRARIES

After setting up the busbar or other geometry, it's convenient to be able to save it for future use, avoiding unnecessary work. In the steps you've just completed, the geometry was stored directly in the COMSOL model file that will also be used to set up the complete busbar model. Instead, you can also create a reusable part that can serve as a building block of a more complex COMSOL model geometry, which is stored in a separate file accessible through the Part Libraries.

While building the busbar geometry, you were using features from the Geometry and Workplane tabs. A Parts menu is located in the Other group in these tabs.

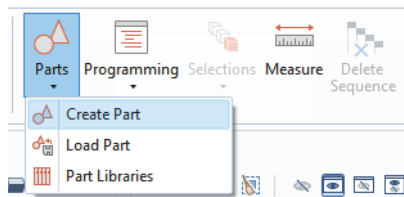

Through the Parts menu, you can choose to create or load a part, or add a part to the model geometry by selecting one from the Part Libraries. Several Part Libraries are already provided with the software by default. When new parts are created, they are added under a Part's parent node in the Global Definitions section of the model tree. For additional information on working with Parts and the Part Libraries, see the *COMSOL Multiphysics Reference Manual*.

! To continue with the busbar tutorial, return to the section “Materials” on page 61.

Appendix B—Keyboard and Mouse Shortcuts

SHORTCUT (WINDOWS, LINUX)	SHORTCUT (OS X)	ACTION
F1	F1	Display help for the selected node or window
Ctrl+F1	Command+F1	Open the COMSOL Documentation front page in an external window
F2	F2	Rename the selected node, file, or folder
F3	F3	Disable selected nodes
F4	F4	Enable selected nodes
F5	F5	Update the Data Sets Solutions with respect to any new Global Definitions and Definitions without re-solving the model
F6	F6	Build the preceding node in the geometry branch
F7	F7	Build the selected node in the geometry and mesh branches, compute the selected study step, or compute the selected node in the solver sequence
F8	F8	Build the geometry, build the mesh, compute the entire solver sequence, update results data, or update the plot
Del	Del	Delete selected nodes
Left arrow (Windows); Shift + left arrow (Linux)	Left arrow	Collapse a branch in the model tree
Right arrow (Windows); Shift + right arrow (Linux)	Right arrow	Expand a branch in the model tree
Up arrow	Up arrow	Move to the node above in the model tree
Down arrow	Down arrow	Move to the node below in the model tree
Alt+left arrow	Ctrl+left arrow	Move to the previously selected node in the model tree

SHORTCUT (WINDOWS, LINUX)	SHORTCUT (OS X)	ACTION
Alt+right arrow	Ctrl+right arrow	Move to the next selected node in the model tree
Ctrl+A	Command+A	Select all domains, boundaries, edges, or points; select all cells in a table
Ctrl+C	Command+C	Copy text in fields
Ctrl+D	Command+D	Clear the selection of domains, boundaries, edges, or points
Ctrl+F	Command+F [[check]]	Find a search string
Ctrl+N	Command+N	New model
Ctrl+O	Command+O	Open a model file
Ctrl+P	Command+P	Print the contents of the plot window
Ctrl+S	Command+S	Save a model file
Ctrl+V	Command+V	Paste copied text
Ctrl+Y	Ctrl+Shift+Z	Redo the last undone operation
Ctrl+Z	Command+Z	Undo the last operation
Ctrl+up arrow	Command+up arrow	Move a definitions node, geometry node, physics node (except default nodes), material node, mesh node, study step node, or results node up one step
Ctrl+down arrow	Command+down arrow	Move a definitions node, geometry node, physics node (except default nodes), material node, mesh node, study step node, or results node down one step
Ctrl+Tab	Ctrl+Tab	Switch focus to the next window on the desktop
Ctrl+Shift+Tab	Ctrl+Shift+Tab	Switch focus to the previous window on the desktop
Ctrl+Alt+A	Not available	Go to Application Builder
Ctrl+Alt+M	Not available	Go to Model Builder
Ctrl+Alt+left arrow	Command+Alt+left arrow	Switch focus to the Model Builder window
Ctrl+Alt+right arrow	Command+Alt+right arrow	Switch focus to the Settings window

SHORTCUT (WINDOWS, LINUX)	SHORTCUT (OS X)	ACTION
Ctrl+Alt+up arrow	Command+Alt+up arrow	Switch focus to the previous section in the Settings window
Ctrl+Alt+down arrow	Command+Alt+down arrow	Switch focus to the next section in the Settings window
Shift+F10 or (Windows only) Menu key	Ctrl+F10	Open the context menu
Ctrl+Space	Ctrl+Space	Open list of predefined quantities for insertion in Expression fields for plotting and results evaluation
Left-click and hold down the mouse button while dragging the mouse.	Same as for Windows, only available for two-button mouse.	Rotate the scene around the axes parallel to the screen X- and Y-axes with the origin at the scene rotation point.
Right-click and hold down the mouse button while dragging the mouse.	Same as for Windows, only available for two-button mouse.	Move the visible frame on the image plane in any direction.
Middle-click and hold down the mouse button while dragging the mouse.	Same as for Windows, only available for two-button mouse.	The scene is zoomed in/out around the mouse position where the action started.
Press Ctrl and left-click. While holding down the key and button, drag the mouse.	Same as for Windows, only available for two-button mouse.	Tilt and pan the camera by rotating about the X- and Y axes in the image plane.
Press Ctrl and right-click. While holding down the key and button, drag the mouse.	Same as for Windows, only available for two-button mouse.	Move the camera in the plane parallel to the image plane.
Press Ctrl and middle-click. While holding down the key and button drag the mouse.	Same as for Windows, only available for two-button mouse.	Move the camera into and away from the object (dolly in/out).
Press Ctrl+Alt and left-click. While holding down the keys and button, drag the mouse.	Same as for Windows, only available for two-button mouse.	Rotate the camera around the axis.
Press Alt and left-click. While holding down the key and button, drag the mouse.	Same as for Windows, only available for two-button mouse.	Rotate the camera about its axis between the camera and the scene rotation point (roll direction).

SHORTCUT (WINDOWS, LINUX)	SHORTCUT (OS X)	ACTION
Press Alt and right-click. While holding down the key and button, drag the mouse.	Same as for Windows, only available for two-button mouse.	Move the scene in the plane orthogonal to the axis between the camera and the scene rotation point.
Press Alt and middle-click. While holding down the key and button, drag the mouse.	Same as for Windows, only available for two-button mouse.	Move the camera along the axis between the camera and the scene rotation point.

Appendix C—Language Elements and Reserved Names

Building a model tree in COMSOL is equivalent to graphically programming a sequence of operations. Saving as model file for MATLAB[®] or for Java[®] outputs the sequence of operations as a list of traditional programming statements. In this section we will give an overview of the following element categories as defined by the underlying COMSOL language:

- Constants
- Variables
- Functions
- Operators
- Expressions

These language elements are built-in or user-defined. Operators cannot be user-defined. Expressions are always user-defined.

ABOUT RESERVED NAMES

Built-in elements have reserved names, names that cannot be redefined by the user. If you try to use a reserved name for a user-defined variable, parameter, or function, the text where you enter the name will turn orange and you will get a tooltip error message if you select the text string. *Reserved function names are reserved only for function names, which means that such names can be used for variable and parameter names, and vice versa.* In the following pages, we list the most commonly used built-in elements and hence those reserved names. A more exhaustive list of built-in elements can be found in the *COMSOL Multiphysics Reference Manual*.

VARIABLES USED IN APPLICATIONS

Model parameters and variables can be used in applications. For example, you can let the user of an application change the value of a parameter. In addition, variables to be used in applications can be defined in the Application Builder under the Declarations node. Such variables are available globally in form objects and methods but cannot be used in the Model Builder.

Constants and Parameters

There are three different types of constants: built-in mathematical and numerical constants, built-in physical constants, and parameters. Parameters are user-defined

constants which can vary over parameter sweeps. Constants are scalar valued. The tables below list the built-in mathematical and numerical constants as well as built-in physical constants. Constants and parameters can have units.

BUILT-IN MATHEMATICAL AND NUMERICAL CONSTANTS

DESCRIPTION	NAME	VALUE
Floating point relative accuracy for double floating point numbers, also known as machine epsilon	<code>eps</code>	2^{-52} ($\sim 2.2204 \cdot 10^{-16}$)
The imaginary unit	<code>i, j</code>	<code>i, sqrt(-1)</code>
Infinity, ∞	<code>inf, Inf</code>	A value larger than what can be handled with floating point representation
Not-a-number	<code>NaN, nan</code>	An undefined or unrepresentable value such as the result of <code>0/0</code> or <code>inf/inf</code>
π	<code>pi</code>	3.141592653589793

BUILT-IN PHYSICAL CONSTANTS

DESCRIPTION	NAME	VALUE
Acceleration of gravity	<code>g_const</code>	9.80665[m/s ²]
Avogadro constant	<code>N_A_const</code>	6.02214129e23[1/mol]
Boltzmann constant	<code>k_B_const</code>	1.3806488e-23[J/K]
Characteristic impedance of vacuum (impedance of free space)	<code>Z0_const</code>	376.73031346177066[ohm]
Electron mass	<code>me_const</code>	9.10938291e-31[kg]
Elementary charge	<code>e_const</code>	1.602176565e-19[C]
Faraday constant	<code>F_const</code>	96485.3365[C/mol]
Fine-structure constant	<code>alpha_const</code>	7.2973525698e-3
Gravitational constant	<code>G_const</code>	6.67384e-11[m ³ /(kg*s ²)]
Molar volume of ideal gas (at 273.15 K and 1 atm)	<code>V_m_const</code>	2.2413968e-2[m ³ /mol]
Neutron mass	<code>mn_const</code>	1.674927351e-27[kg]
Permeability of vacuum (magnetic constant)	<code>mu0_const</code>	4*pi*1e-7[H/m]

DESCRIPTION	NAME	VALUE
Permittivity of vacuum (electric constant)	<code>epsilon0_const</code>	$8.854187817000001e-12$ [F/m]
Planck's constant	<code>h_const</code>	$6.62606957e-34$ [J*s]
Planck's constant over 2 pi	<code>hbar_const</code>	$1.05457172533629e-34$ [J*s]
Proton mass	<code>mp_const</code>	$1.672621777e-27$ [kg]
Speed of light in vacuum	<code>c_const</code>	299792458 [m/s]
Stefan-Boltzmann constant	<code>sigma_const</code>	$5.670373e-8$ [W/(m ² *K ⁴)]
Universal gas constant	<code>R_const</code>	8.3144621 [J/(mol*K)]
Wien displacement law constant	<code>b_const</code>	$2.8977721e-3$ [m*K]

PARAMETERS

Parameters are user-defined constant scalars in the Global Definitions branch in the model tree. Example uses are:

- Parameterizing geometric dimensions
- Parameterizing mesh element sizes
- Defining parameters to be used in parametric sweeps

A parameter can be defined as an expression in terms of numbers, parameters, built-in constants, and built-in functions of parameters and built-in constants. Parameters should be assigned a unit, using [], unless they are dimensionless.

Variables

There are two types of variables: built-in and user-defined. Variables can be scalars or fields. Variables can have units.

Note: There is a group of user-defined variables of special interest. Spatial coordinate variables and dependent variables. These variables have default names based on the space dimension of the geometry and the physics interface respectively. As a result of the names chosen for these variables, a list of built-in variables will be created by COMSOL: the first and second order derivatives with respect to space and time.

BUILT-IN VARIABLES

NAME	DESCRIPTION	TYPE
t	Time	Scalar
freq	Frequency	Scalar
lambda	Eigenvalue	Scalar
phase	Phase angle	Scalar
numberofdofs	Number of degrees of freedom	Scalar
h	Mesh element size (length of the longest edge of the element)	Field
meshtype	Mesh type index for the mesh element; this is the number of edges in the element.	Field
meshelement	Mesh element number	Field
dvol	Volume scale factor variable; this is the determinant of the Jacobian matrix for the mapping from local (element) coordinates to global coordinates.	Field
qual	A mesh quality measure between 0 (poor quality) and 1 (perfect quality)	Field

USER-DEFINED VARIABLES THAT GENERATE BUILT-IN VARIABLES

DEFAULT NAME	DESCRIPTION	TYPE
x, y, z	Spatial coordinates (Cartesian)	Field
r, phi, z	Spatial coordinates (Cylindrical)	Field
u, T, etc.	Dependent variables (Solution)	Field

Example: T is the name for the temperature in a 2D, time-dependent heat transfer model, x and y are the spatial coordinate names. In this case, the following built-in variables will be generated: T, Tx, Ty, Txx, Txy, Tyx, Tyy, Tt, Txt, Tyt, Txxt, Txyt, Tyxt, Tyyt, Ttt, Txxtt, Tytt, Txxtt, Txytt, Tyxtt, and Tyytt. Here, Tx corresponds to the partial derivative of the temperature T with respect to x, and Ttt corresponds to the second-order time derivative of T, and so on. If the spatial coordinate variables have other names—for example, psi and chi—then Txy would be Tpsichi, and Txt would be Tpsit. (The time variable t is built-in; the user cannot change its name.)

Functions

There are two types of functions: built-in and user-defined. Functions can be scalar valued or field valued depending on the input argument(s). Some functions can have units for both input and output arguments.

BUILT-IN MATHEMATICAL FUNCTIONS

These functions do not have units for their input or output arguments.

NAME	DESCRIPTION	SYNTAX EXAMPLE
abs	Absolute value	abs(x)
acos	Inverse cosine (in radians)	acos(x)
acosh	Inverse hyperbolic cosine	acosh(x)
acot	Inverse cotangent (in radians)	acot(x)
acoth	Inverse hyperbolic cotangent	acoth(x)
acsc	Inverse cosecant (in radians)	acsc(x)
acsch	Inverse hyperbolic cosecant	acsch(x)
arg	Phase angle (in radians)	arg(x)
asec	Inverse secant (in radians)	asec(x)
asech	Inverse hyperbolic secant	asech(x)
asin	Inverse sine (in radians)	asin(x)
asinh	Inverse hyperbolic sine	asinh(x)
atan	Inverse tangent (in radians)	atan(x)
atan2	Four-quadrant inverse tangent (in radians)	atan2(y, x)
atanh	Inverse hyperbolic tangent	atanh(x)
besselj	Bessel function of the first kind	besselj(a, x)
bessely	Bessel function of the second kind	bessely(a, x)
besseli	Modified Bessel function of the first kind	besseli(a, x)
besselk	Modified Bessel function of the second kind	besselk(a, x)
ceil	Nearest following integer	ceil(x)
conj	Complex conjugate	conj(x)
cos	Cosine	cos(x)
cosh	Hyperbolic cosine	cosh(x)
cot	Cotangent	cot(x)
coth	Hyperbolic cotangent	coth(x)

NAME	DESCRIPTION	SYNTAX EXAMPLE
csc	Cosecant	csc(x)
csch	Hyperbolic cosecant	csch(x)
erf	Error function	erf(x)
exp	Exponential	exp(x)
floor	Nearest previous integer	floor(x)
gamma	Gamma function	gamma(x)
imag	Imaginary part	imag(u)
log	Natural logarithm	log(x)
log10	Base-10 logarithm	log10(x)
log2	Base-2 logarithm	log2(x)
max	Maximum of two arguments	max(a,b)
min	Minimum of two arguments	min(a,b)
mod	Modulo operator	mod(a,b)
psi	Psi function and its derivatives	psi(x,k)
range	Create a range of numbers	range(a,step,b)
real	Real part	real(u)
round	Round to closest integer	round(x)
sec	Secant	sec(x)
sech	Hyperbolic secant	sech(x)
sign	Signum function	sign(u)
sin	Sine	sin(x)
sinh	Hyperbolic sine	sinh(x)
sqrt	Square root	sqrt(x)
tan	Tangent	tan(x)
tanh	Hyperbolic tangent	tanh(x)

BUILT-IN OPERATOR FUNCTIONS

These built-in functions behave differently than the built-in mathematical functions. They may not belong in an introductory text but are listed to complete

the list of reserved names. For more information see the *COMSOL Multiphysics Reference Manual*.

NAME	NAME	NAME	NAME
adj	dtang	linsol	sens
at	emetric	lintotal	shapeorder
ballavg	env	lintotalavg	side
ballint	error	lintotalpeak	sphavg
bdf	fsens	lintotalrms	sphint
bdenv	fsensimag	linzero	subst
centroid	if	mean	sum
circavg	integrate	noenv	test
circint	isdefined	nojac	timeavg
circumcenter		pd	timeint
d	isinf	ppr	try_catch
depends	islinear	pprint	up
dest	isnan	prev	var
diskavg	jacdepends	reactf	with
diskint	lindev	realdot	
down	linper	residual	
	linpoint	scope.ati	

USER-DEFINED FUNCTIONS

A user-defined function can be defined in the Global Definitions or Component Definitions branch of the model tree by selecting a template from the Functions menu and entering settings to define the name and detailed shape of the function.

TEMPLATE NAME	ARGUMENTS AND DEFINITION	SYNTAX EXAMPLE
Analytic	<p>The function name is its identifier; for example an1.</p> <p>The function is a mathematical expression of its arguments.</p> <p>Example: Given the arguments x and y, its definition is sin(x)*cos(y).</p> <p>The function has an arbitrary number of arguments.</p>	<p>The name of the function with comma-separated arguments within parenthesis. For example:</p> <p>an1(x,y)</p>
Elevation	<p>The function name is its identifier; for example elev1.</p> <p>Used to import geospatial elevation data from digital elevation models and map the elevation data to a function of x and y. A DEM file contains elevation data for a portion of the Earth's surface. The resulting function behaves essentially like a grid-based interpolation function.</p>	<p>The name of the function with comma-separated arguments within parenthesis. For example:</p> <p>elev1(x,y)</p>
Gaussian Pulse	<p>The function name is its identifier; for example gp1.</p> <p>The Gaussian pulse function defines a bell-shaped curve according to the expression</p> $y(x) = \frac{1}{\sigma\sqrt{2\pi}} e^{-\frac{(x-x_0)^2}{2\sigma^2}}$ <p>It is defined by the mean parameter; x_0, and the standard deviation, σ.</p> <p>The function has one argument.</p>	<p>The name of the function with a single argument within parenthesis. For example:</p> <p>gp1(x)</p>

TEMPLATE NAME	ARGUMENTS AND DEFINITION	SYNTAX EXAMPLE
Image	<p>The function name is its identifier; for example im1.</p> <p>Used to import an image (in BMP, JPEG, PNG, or GIF format) and map the image's RGB data to a scalar (single channel) function output value. By default the function's output uses the mapping $(R+G+B)/3$.</p>	<p>The name of the function with comma-separated arguments within parenthesis. For example:</p> <p>im1 (x, y)</p>
Interpolation	<p>The function name is its identifier; for example int1.</p> <p>An interpolation function is defined by a table or file containing the values of the function in discrete points.</p> <p>The file formats are the following: spreadsheet, grid, or sectionwise.</p> <p>The function has one to three arguments.</p>	<p>The name of the function with comma-separated arguments within parenthesis. For example:</p> <p>int1 (x, y, z)</p>
Piecewise	<p>The function name is its identifier; for example pw1.</p> <p>A piecewise function is created by splicing together several functions, each defined on one interval. Define the argument, extrapolation and smoothing methods, and the functions and their intervals.</p> <p>This function has one argument with different definitions on different intervals, which must not overlap or have any holes between them.</p>	<p>The name of the function with a single argument within parenthesis. For example:</p> <p>pw1 (x)</p>
Ramp	<p>The function name is its identifier; for example rm1.</p> <p>A ramp function is a linear increase with a user-defined slope that begins at some specified time.</p> <p>The function has one argument. It can also be smoothed.</p>	<p>The name of the function with a single argument within parenthesis. For example:</p> <p>rm1 (x)</p>

TEMPLATE NAME	ARGUMENTS AND DEFINITION	SYNTAX EXAMPLE
Random	<p>The function name is its identifier; for example rn1.</p> <p>A random function generates white noise with uniform or normal distribution and has one or more arguments to simulate white noise. The function has arbitrary number of arguments.</p>	<p>The name of the function with comma-separated arguments within parenthesis. For example:</p> <p>rn1(x,y)</p> <p>The arguments x and y are used as a random seeds for the random function.</p>
Rectangle	<p>The function name is its identifier; for example rect1.</p> <p>A rectangle function is 1 in an interval and 0 everywhere else. The function has one argument.</p>	<p>The name of the function with a single argument within parenthesis. For example:</p> <p>rect1(x)</p>
Step	<p>The function name is its identifier; for example step1.</p> <p>A step function is a sharp transition from 0 to some other value (amplitude) at some location. The function has one argument. It can also be smoothed.</p>	<p>The name of the function with a single argument within parenthesis. For example:</p> <p>step1(x)</p>
Triangle	<p>The function name is its identifier; for example tri1.</p> <p>A triangle function is a linear increase and linear decline within an interval and 0 everywhere else. The function has one argument. It can also be smoothed.</p>	<p>The name of the function with a single argument within parenthesis. For example:</p> <p>tri1(x)</p>
Waveform	<p>The function name is its identifier; for example wv1.</p> <p>A waveform function is a periodic function with one of several characteristic shapes: sawtooth, sine, square, or triangle. The function has one argument. It can also be smoothed.</p>	<p>The name of the function with a single argument within parenthesis. For example:</p> <p>wv1(x)</p>

TEMPLATE NAME	ARGUMENTS AND DEFINITION	SYNTAX EXAMPLE
External (Global Definitions only)	An external function defines an interface to one or more functions written in the C language (which can be a wrapper function interfacing source code written in for example Fortran). Such an external function can be used, for example, to interface a user-created shared library. Note that the extension of a shared library file depends on the platform: .dll (Windows), .so (Linux), or .dylib (OS X).	The name of the function and the appropriate number of arguments within parenthesis. For example: myextfunc(a,b)
MATLAB [®] (Global Definitions only)	A MATLAB [®] function interfaces one or more functions written in the MATLAB [®] language. Such functions can be used as any other function defined in COMSOL provided LiveLink [™] for MATLAB [®] and MATLAB [®] are installed. (MATLAB [®] functions are evaluated by MATLAB [®] at runtime.)	The name of the function and the appropriate number of arguments within parenthesis. For example: mymatlabfunc(a,b)

Unary and Binary Operators

PRECEDENCE LEVEL	SYMBOL	DESCRIPTION
1	() { } .	Grouping, Lists, Scope
2	^	Power
3	! - +	Unary: Logical Not, Minus, Plus
4	[]	Unit
5	* /	Multiplication, Division
6	+ -	Binary: Addition, Subtraction
7	< <= > >=	Comparisons: Less-Than, Less-Than or Equal, More-Than, More-Than or Equal
8	== !=	Comparisons: Equal, Not Equal
9	&&	Logical And
10		Logical Or
11	,	Element Separator in Lists

Expressions

PARAMETERS

A parameter expression can contain: numbers, parameters, built-in constants, built-in functions of parameter expressions, unary and binary operators. Parameters can have units.

VARIABLES

A variable expression can contain: numbers, parameters, constants, variables, functions of variable expressions, unary and binary operators. Variables can have units.

FUNCTIONS

A function definition can contain: input arguments, numbers, parameters, constants, functions of parameter expressions including input arguments, unary and binary operators.

Appendix D—File Formats

COMSOL File Formats

The COMSOL Model file type, with the extension `.mph`, is the default file type containing the entire model tree. The file contains both binary and text data. The mesh and solution data are stored as binary data, while all other information is stored as plain text.

Files with the extension `.mph` also contain an application that can be run in COMSOL Multiphysics, the COMSOL client for Windows[®], or through a web browser. See the *COMSOL Multiphysics Reference Manual* and the *Application Builder Reference Manual* for more information.

The COMSOL binary and text file types, with the extension `.mphbin` and `.mphtxt`, respectively, contain either geometry objects or mesh objects which can be imported directly to the Geometry or Mesh branches in the model tree.

The Physics Builder file type, with the extension `.mphphb`, contains one or more physics interfaces that you can access from the Model Wizard. See the *Physics Builder Manual*, for more information.

See “Supported External File Formats” for more information about all the other formats supported by COMSOL.

FILE TYPE	EXTENSION	READ	WRITE
COMSOL Model and Application	<code>.mph</code>	Yes	Yes
Binary Data	<code>.mphbin</code>	Yes	Yes
Text Data	<code>.mphtxt</code>	Yes	Yes
Physics Builder	<code>.mphphb</code>	Yes	Yes

Supported External File Formats

CAD

The CAD Import Module, Design Module and LiveLink products for CAD allow for import of a range of industry-standard CAD file types. Additional file types are available through the bidirectional functionality of the LiveLink products for CAD as well as with the File Import for CATIA[®] V5 add-on.

The DXF (2D), VRML (3D), and STL (3D) file types are available for import with COMSOL Multiphysics and don't require any add-on products. Unless noted otherwise in the table below, import of the listed file types is available on all by COMSOL supported versions of Linux®, Mac OS X, and Windows® operating systems.

FILE TYPE	EXTENSION	READ	WRITE
AutoCAD® ^{1,2,3}	.dwg	Yes	Yes ⁹
Inventor® ^{1,2,3}	.ipt, .iam	Yes	Yes ⁹
NX® ^{1,4}	.prt	Yes	No
PTC® Creo® Parametric™ ^{1,3}	.prt, .asm	Yes	Yes ⁹
PTC® Pro/ENGINEER® ^{1,3}	.prt, .asm	Yes	Yes ⁹
Revit® Architecture ^{3,5}	.rvt	Yes ⁹	Yes ⁹
Solid Edge® ^{3,6}	.par, .asm	Yes ⁹	Yes ⁹
SOLIDWORKS® ^{1,2,3}	.sldprt, .sldasm	Yes	Yes ⁹
DXF (3D ^{1,2} and 2D)	.dxf	Yes	Yes ¹⁰
Parasolid® ¹	.x_t, .xmt_txt, .x_b, .xmt_bin	Yes	Yes
ACIS® ¹	.sat, .sab, .asat, .asab	Yes	Yes
STEP ¹	.step, .stp	Yes	No
IGES ¹	.iges, .igs	Yes	No
CATIA® V5 ^{2,7}	.CATPart, .CATProduct	Yes	No
VRML, vI ⁸	.vrmI, .wrl	Yes	No

FILE TYPE	EXTENSION	READ	WRITE
STL ⁸	.stl	Yes	Yes

¹Requires one of the LiveLink™ products for AutoCAD®, Revit®, PTC® Creo® Parametric™, Inventor®, PTC® Pro/ENGINEER®, Solid Edge®, SOLIDWORKS®; or the CAD Import Module; or the Design Module

²Import supported on Windows® operating systems only

³Synchronization of files between COMSOL and a linked CAD program supported on Windows® 7, 8, and 8.1 operating systems only

⁴Import supported on Windows® and Linux operating systems only

⁵Requires LiveLink™ for Revit®

⁶Requires LiveLink™ for Solid Edge®

⁷Requires the CAD Import Module (or the Design Module, or one of the LiveLink™ products for AutoCAD®, PTC® Creo® Parametric™, Inventor®, PTC Pro/ENGINEER®, Solid Edge®, or SOLIDWORKS®) and the File Import for CATIA® V5

⁸Limited to a single geometric domain

⁹From/To file using linked CAD package provided the original CAD geometry is created in the CAD package

¹⁰Writing to file is supported for 2D geometry only

ECAD

The ECAD Import Module allows for import of 2D layout files with automatic conversion to 3D CAD models. The Touchstone file type is used for exporting S-parameters, impedance, and admittance values from simultaneous port and frequency sweeps. The SPICE Circuit Netlist file type is converted at import to a series of lumped circuit element nodes under an Electrical Circuit node.

FILE TYPE	EXTENSION	READ	WRITE
NETEX-G ¹	.asc	Yes	No
ODB++ ¹	.zip, .tar, .tgz, .tar.gz	Yes	No
ODB++(X) ¹	.xml	Yes	No
GDS ¹	.gds	Yes	No
Touchstone ²	.s2p, .s3p, .s4p, ...	No	Yes
SPICE Circuit Netlist ³	.cir	Yes	No

¹Requires the ECAD Import Module

²Requires one of the AC/DC, RF, MEMS, or Wave Optics Modules

³Requires one of the AC/DC, RF, MEMS, Plasma, or Semiconductor Modules

MATERIAL DATABASES

The Chemical Reaction Engineering Module can read CHEMKIN[®] files to simulate complex chemical reactions in the gas phase. The Plasma Module can read LXCAT files for sets of electron impact collision cross sections.

FILE TYPE	EXTENSION	READ	WRITE
CHEMKIN [®] ¹	.dat, .txt, .inp ³	Yes	No
CAPE-OPEN ¹ (direct connection)	n/a	n/a	n/a
LXCAT file ²	.lxcat, .txt	Yes	No

¹Requires the Chemical Reaction Engineering Module

²Requires the Plasma Module

³Any extension is allowed; these are the most common extensions

MESH

The NASTRAN[®] Bulk Data file types are used to import a volumetric mesh. The VRML and STL file types are used to import a triangular surface mesh, and cannot be used for creating a volumetric mesh. If imported as a Geometry, VRML and STL files can be used as a basis for creating a volumetric mesh for a single geometric domain.

FILE TYPE	EXTENSION	READ	WRITE
NASTRAN [®] Bulk Data	.nas, .bdf, .nastran, .dat	Yes	Yes
VRML, v1	.vrml, .wrl	Yes	No
STL	.stl	Yes	Yes

IMAGES AND MOVIES

Results visualization can be exported to a number of common image file types, see the table below. Images can also be read and used as interpolation functions for physics modeling. Animations can be exported to one of the Animated GIF, Adobe[®] Flash[®], and AVI file types.

FILE TYPE	EXTENSION	READ	WRITE
JPEG	.jpg, .jpeg	Yes	Yes
PNG	.png	Yes	Yes
BMP	.bmp	Yes	Yes
TIFF	.tif, .tiff	No	Yes
GIF	.gif	Yes	Yes

FILE TYPE	EXTENSION	READ	WRITE
EPS (ID graphs only)	.eps	No	Yes
Animated GIF	.gif	No	Yes
Adobe® Flash®	.swf	No	Yes
AVI ¹	.avi	No	Yes

¹ Available for Windows® only

PROGRAMMING LANGUAGES AND SPREADSHEET

Model files for Java® are editable script files, with the extension *.java*, that contain sequences of COMSOL commands as Java® code. Edit the files in a text editor to add additional commands. You can compile these Java® files into Java® Class files, with the extension *.class*, and run them as separate applications.

Model files for MATLAB® are editable script files (M-files), similar to the model files for Java®, for use with MATLAB®. These model files, which have the extension *.m*, contain a sequence of COMSOL commands as a MATLAB® M-file. You can run the model files in MATLAB® like any other M-file scripts. It is also possible to edit the files in a text editor to include additional COMSOL commands or general MATLAB® commands. Running model files in the M-file format requires the COMSOL LiveLink™ for MATLAB®.

FILE TYPE	EXTENSION	READ	WRITE
MATLAB®: model file for MATLAB®	.m	No	Yes
MATLAB®: Function ¹	.m	Yes	No
Java®: model file for Java®	.java	No	Yes
Java®: compiled model file for Java®	.class	Yes	No
C: Function	.dll ³ , .so ⁴ , .dylib ⁵	Yes	No
Excel® ²	.xlsx	Yes	Yes

¹ Requires LiveLink™ for MATLAB®

² Requires LiveLink™ for Excel®, available for Windows® only

³ Available for Windows® only

⁴ Available for Linux® only

⁵ Available for OS X only

NUMERICAL AND INTERPOLATION DATA FORMATS

The grid, sectionwise, and spreadsheet file types can be read for defining interpolation functions. The sectionwise and spreadsheet file types can

furthermore be read and used for defining interpolation curves and written for exporting results. In addition, tables can be copy-pasted on spreadsheet format. Parameters and variables can be imported and exported to the plain text, comma-separated values, or data file types.

The continuous and discrete color table text file types are used for user-defined color tables for results visualization.

Digital elevation model (DEM) files can be read and used as a parametric surface for defining a geometry.

FILE TYPE	EXTENSION	READ	WRITE
Copy and paste spreadsheet format	n/a	Yes	Yes
Excel® spreadsheet ¹	.xlsx	Yes	Yes
Table	.txt, .csv, .dat	Yes	Yes
Grid	.txt	Yes	Yes
Sectionwise	.txt, .csv, .dat	Yes	Yes
Spreadsheet	.txt, .csv, .dat	Yes	Yes
Parameters	.txt, .csv, .dat	Yes	Yes
Variables	.txt, .csv, .dat	Yes	Yes
Continuous and Discrete color table	.txt	Yes	No
Point data for Cut Point data sets	.txt	Yes	No
DEM	.dem	Yes	No

¹Requires LiveLink™ for Excel®, available for Windows® only

Appendix E—Connecting with LiveLink™ Add-Ons

The following table shows the options to start COMSOL and the different linked partner software using the LiveLink add-ons.

COMSOL® Software	Can Start COMSOL from Partner Software	Can Start Partner Software from COMSOL	Can Connect Running Sessions
LiveLink™ for Excel®	Yes ¹	Yes ²	No
LiveLink™ for MATLAB®	Yes ³	Yes ⁴	Yes ⁵
LiveLink™ for AutoCad®	No	No	Yes
LiveLink™ for Revit®	No	No	Yes
LiveLink™ for PTC®Creo® Parametric™	No	No	Yes
LiveLink™ for Inventor®			
- Bidirectional Mode	No	No	Yes
- One Window Mode	Yes	No	No
LiveLink™ for PTC® Pro/ENGINEER®	No	No	Yes
LiveLink™ for Solid Edge®	No	No	Yes
LiveLink™ for SOLIDWORKS®			
- Bidirectional Mode	No	No	Yes
- One Window Mode	Yes	No	No

¹When you open a COMSOL model from Excel®, a COMSOL model window starts and a link is established automatically. The COMSOL model window is an output window that displays geometry, mesh, and results.

- ²A COMSOL model that includes a table reference to an Excel[®] spreadsheet automatically starts an Excel[®] process in the background when the model is run in COMSOL Desktop environment.
- ³You can start a COMSOL Multiphysics Server from a MATLAB[®] session using the **system** command and then connect to it using **mphstart** in the MATLAB[®] command prompt.
- ⁴The “COMSOL 5.2 with MATLAB[®]” desktop shortcut starts a COMSOL Multiphysics Server and MATLAB[®], then connects them automatically. When you run a COMSOL model in the COMSOL Desktop interface that includes a MATLAB[®] function (Global Definitions>Functions), a MATLAB[®] engine and connection is started automatically.
- ⁵You can connect a MATLAB[®] session to a running COMSOL Multiphysics Server using the COMSOL command **mphstart** in the MATLAB[®] command prompt.

Index

- A**
 - AC/DC Module 54
 - accuracy
 - convergence analysis 47
 - recover option 44
 - Add Material window
 - busbar model 62
 - opening 35, 61
 - add-on modules
 - AC/DC 54
 - Application Libraries, and 26
 - CAD Import 136, 168
 - CFD 109
 - Chemical Reaction Engineering 171
 - ECAD Import 170
 - MEMS 102
 - physics list, and 31, 55
 - Plasma 171
 - Structural Mechanics 30, 40
 - study types, and 56
 - advanced study options 132
 - advanced topics 94
 - analysis
 - convergence 47
 - example, parametric sweep 51
 - application 11, 82
 - Application Builder 6, 8, 10, 11, 21, 82, 155
 - Application Libraries
 - examples 26
 - file types 27
 - MPH-files 26
 - opening 26
 - Application Library Update 27
 - average temperature 126
- B**
 - blank model, creating 13, 15
 - boundaries 68
 - adding to selection 70
 - variables scope 21
 - boundary condition 66
 - automatically defined 40
 - boundary load 39
 - busbar, setting 66
 - electric current 66, 69
 - fixed constraint 38
 - free 37
 - ground, electrical 71
 - heat transfer 66
 - insulating 68
 - material interface 40
 - settings window, and 8
 - boundary load 40
 - boundary section
 - context menu, and 67
 - boundary selection, busbar model 68
 - Build All button
 - geometry 59
 - meshes 40, 73
 - built-in
 - constants, functions, and variables 22
 - materials 35, 61
 - variables 77
 - button object 85
- C**
 - CAD Import Module 136, 168
 - cancel button 10
 - CFD Module 109
 - Chemical Reaction Engineering Module 171
 - cloud computing 132
 - Cluster Computing node 132
 - Cluster Sweep node 132

- command sequence 88
- Compact MPH-files 27
- component coupling 126
- Component node, adding materials 62
- computing studies 51
- COMSOL Client 11
- COMSOL Desktop environment
 - customizing 23
 - on Linux 17
 - on OS X 17
 - overview 6
- COMSOL Multiphysics 11
 - native CAD format 33
 - opening 31
- COMSOL Server 11
- constants
 - mathematical and physical types 22
- context menu
 - domain and boundary sections 67
- contextual tab 16
- convergence analysis 47, 52
- Convergence plot 9, 73
- cooling
 - air stream 53
 - natural convection 57
- coupling operator 126
- Create Selection button 105
- custom studies 56
- customized desktop 23

D

- data sets, defined 18
- default feature 66
- Definitions node 29
- degrees of freedom 47, 52
- derivatives 23
- Derived Values
 - defined 18
 - Global Evaluation 52
 - Volume Maximum 47, 51, 81
- Direct solver 42
- DirectX 12
- discretize 40
- documentation, models 26
- domain level 67
- domain section
 - context menu, and 67
- domains
 - materials 64
 - physics 38
 - remove from selection 64
 - variables scope 21
- dynamic help 10

E

- ECAD Import Module 170
- edges
 - variables scope 21
- Editor Templates window 87
- eigenfrequency analysis 18
- Electric Currents interface
 - defining boundary conditions 67
 - multiphysics, and 56, 71
 - overview 66
- electric potential 54
 - physics node 69
 - voltage drop, parameter 57
- electrical heating 53
- equation
 - built-in 66
 - user-defined 45
- error message, insufficient memory 42
- evaluating
 - volume maximum 48, 79, 81
 - von Mises stress 48
- example
 - advanced, electrical heating 53
 - basic, structural mechanics 30
- Excel® 174
- Export node, defined 18
- exporting images 81
- expressions

- Boolean 46
 - manual entry 48, 57
 - replacing 46, 77, 79
 - units, specifying 48
 - user-defined 45
- External Process window 10
- F**
 - finite element
 - mesh 40
 - preconditioning 51
 - sparse matrix 42
 - tetrahedrons 40
 - Fixed Constraint node 38
 - Floating Network License 132
 - Form editor 10, 85
 - form objects 82
 - form union, geometry 59
 - frequency response 19
 - frequency-domain study 18
 - Full MPH-files 27
 - functions
 - advanced topics 94
 - built-in 22
 - mathematical 23
 - ppr(), recover option 48
 - scope 57
 - Functions node 57
- G**
 - geometric dimensions
 - parameters, and 20
 - parametric sweep 57
 - geometry
 - building 57
 - CAD format 32
 - importing 32
 - in Application Libraries 58
 - loading from file 57, 58
 - parameterized 20, 57, 59
 - settings window 8
 - Geometry node 28
 - Global Definitions node 17
 - functions 57
 - parameters 57
 - scope 21, 57
 - variables 20
 - global parameters 20, 36, 49
 - graphics
 - rendering and hardware 12
 - graphics object 84, 86
 - Graphics toolbar
 - default view button 38, 45, 71, 78
 - image snapshot button 82
 - zoom extents button 60, 75
 - Graphics window 9
 - geometry, and 34
 - plot 43
 - rotate geometry 38, 74, 76
 - selecting boundary 38, 39, 71
 - using 34, 61
 - zoom box 39
 - Ground, boundary condition 70
- H**
 - Heat Transfer in Solids interface
 - defining boundary conditions 67
 - multiphysics, and 56, 71
 - overview 66
 - Heat Transfer Module 109
 - Help window
 - defined 10
 - opening 17
 - high performance computing 132
 - Home tab 15
 - HPC 132
 - hybrid parallelism 134
- I**
 - Image Snapshot button 82
 - images, creating thumbnails 81
 - importing geometry 32, 33
 - infinite elements 29
 - information windows 9

- initial conditions 8
- Initial Values node
 - Electric Currents interface 67
 - Heat Transfer in Solids interface 67
 - Solid Mechanics interface 37
- input fields 83
- Insert Object menu 87
- Isosurface plot 74
- iterative solver
 - multigrid 51
 - preconditioning 51
- J**
 - Java 172
 - Java-file 29
 - Joule heating
 - equations 66
 - multiphysics coupling 71
 - Joule Heating multiphysics interface 55
- L**
 - Laminar Flow interface 113
 - Linux version 17
 - LiveLink™ add-ons 174
 - Log window 9, 43
 - LU factorization 42
- M**
 - Material Browser
 - defined 10
 - material contents section 35, 63
 - material interface
 - mechanical contact 40
 - visualization accuracy 44
 - materials
 - copper 53
 - domains, assigning 63
 - model tree 28
 - settings window 8
 - steel 35, 45
 - titanium alloy 53
 - Materials node 35, 61
 - mathematical constants and functions
 - 22
 - MATLAB® 172
 - matrix 42
 - matrix equation system 42
 - Max/Min Volume plot 48
 - Maximum and minimum values table 80
 - memory requirements (RAM) 41
 - MEMS Module
 - thermal expansion, and 102
 - mesh
 - convergence analysis, and 47
 - density 49
 - finite element 40
 - model tree, and 29
 - parameterizing 49, 71
 - physics-controlled, default 71
 - refining 49
 - settings 40
 - unstructured tetrahedral 71
 - user-controlled 50, 72
 - mesh element size
 - parameters, defining 20, 72
 - settings 40
 - Message Passing Interface 134
 - Messages window 9, 43
 - method 91
 - Method editor 10, 91
 - M-file 29
 - modal tab 16
 - Model Builder 82
 - defined 10
 - example 28
 - expanding sections 66
 - geometry import 33
 - node sequence example 37
 - the ribbon, and 16
 - model history 29
 - model tree
 - building 17
 - defined 57

- example 28
- geometry 28
- Global Definitions node 17, 36, 57
- Materials node 28, 35
- Model Builder, and 10
- nodes, and 17
- Results node 18
- root node 17
- Study node 18, 29
- the ribbon, and 16
- Model Wizard
 - adding physics 18, 31, 55
 - Component node, and 18
 - creating a new model 13
 - custom studies 32, 56
 - opening 31, 54
 - preset studies 32, 56
 - space dimension 31, 55
 - study 18, 56
- models
 - defining 10
 - discretization 40
 - documentation 26
 - saving 61
 - structural mechanics 30
 - symmetry 76
 - workflow 28
- MPH-files
 - full and compact 27
 - saving 61, 82
- MPI 134
- multicore processors 132
- multiphysics models 53
- Multiphysics node 66, 67, 71, 104
- multiphysics phenomena 53
- Multislice plot 74
- N** New Form wizard 82
- nodes 17
 - default feature 37
 - reordering 29
- O** OpenGL 12
- OS X version 17
- P** parallel computing 132
- Parameter settings
 - expression 49
 - name 49
- parameters 20, 84
 - defining 49, 57
 - editing 59
 - expression 20
 - global 20
 - meshes, and 49
 - range of values 51
 - scope 57
 - using, referencing 69
- Parameters node 57, 94
- parametric study 57
- parametric sweep 20
 - example 50
 - meshes, and 49
 - range, defining 51
- Perfectly Matched Layer (PML) 29
- physics
 - adding 55
 - boundary conditions 66
 - electromagnetic heating 55
 - heat transfer 55
 - Joule heating 53, 66
 - laminar flow 113
 - model tree, and 28
- physics interface 13
 - Electric Currents 56
 - Heat Transfer in Solids 56
 - Joule Heating 55
 - Laminar Flow 113
 - Solid Mechanics 31
- Plasma Module 171

- Plot Group *18*
 - 3D, adding *45*
 - plots *45*
 - expression, user-defined *45*
 - max/min volume *48*
 - model tree, and *29*
 - regenerating *45, 49*
 - surface *43, 46*
 - windows *9*
 - points, variables scope *21*
 - polynomial functions *40*
 - polynomial-preserving recovery *48*
 - preconditioning *51*
 - preferences *12*
 - preset studies *56*
 - principal stress *109*
 - program code
 - model file for Java *29*
 - model M-file *29*
 - progress bar *10*
 - Progress window *9*
- Q** Quick Access Toolbar *8, 16*
- R** Record Code *92*
- renaming plot groups *46*
 - rendering options *12*
 - reports, defined *18*
 - reserved name *22*
 - resolution of curvature, mesh *72*
 - results
 - color table range *74, 77*
 - derived values *47, 51, 81*
 - displaying *43*
 - quality, accuracy *44*
 - recover option *44, 46, 48*
 - surface settings, modify *74*
 - units, changing *43*
 - Results node
 - 3D plot group *48, 76*
 - busbar defaults *74*
 - subnodes *18*
 - surface node, adding *76*
 - ribbon
 - Add Material *35, 65, 112*
 - Build All *60*
 - Build Mesh *73*
 - Compute *51, 107, 122*
 - defined *8, 15*
 - example *6*
 - importing geometry *33*
 - Model Builder, and *16*
 - Physics tab *38, 104*
 - Windows *10, 43, 139*
 - Work Plane *137*
 - root node
 - default units, and *125*
 - defined *17*
 - model thumbnails, and *81*
 - Model Wizard, and *31*
 - running simulations *73*
- S** saving files *61, 82*
- scope
 - global definitions *57*
 - parameters and variables *21*
 - parameters and variables, defined *20*
 - variable name *22*
 - Select Study window *15*
 - Selection *105*
 - Selection List window *10, 139*
 - selection of multiple boundaries *105*
 - Settings windows *8, 17*
 - shared memory parallelism *132*
 - simulation, running *73*
 - Software Rendering *12*
 - Solid Mechanics interface *31*
 - add-on modules, and *102*
 - solvers
 - configurations *42, 51*

- default settings 41
- default settings, changing 42
- direct 42
- iterative 50, 51
- memory requirements 41
- memory-limited settings 42
- stationary 41, 51
- using 41
- space dimension 13
- sparse matrix equation system 42
- Stationary study 32, 41
- steady-state study 18
- structural analysis 30
- structural displacement field 40
- structural mechanics
 - design 47
 - plastic deformation 45
 - stresses and strains 53, 63
 - von Mises stress 43
- Structural Mechanics Module
 - application library 30
 - mechanical contact, and 40
 - thermal expansion, and 102
- studies
 - computing solutions 51, 73
 - defining 41
 - example, multigrid iterative 51
 - example, stationary 41
 - model tree, and 29
 - preset 56
 - types 18
- Study node 18
 - solution sequence 73
- Surface plot
 - busbar results 74
 - color table range 77
 - deformation 43
 - electrical current density 76
 - replace expression 77

- settings 46
- updating 75, 77

T table

- Maximum and minimum 80

 Table window 10

- graph plot 52
- wrench results 48

 Tables node 18

- tables, evaluating 52
- temperature 74, 123
- temperature, average 126
- Test Application 86
- tetrahedron, polynomial functions 40
- thermal expansion 53, 63
- thumbnail image 81
- time-dependent study 18
- torque, applied 30

U unit, changing 43, 108

user interface

- COMSOL Desktop 6
- overview 6

 user-controlled mesh 50

V variables

- advanced topics 94
- built-in 22
- example, built-in 52
- expression 21
- scope 57
- scope, limit 21

 Variables node 20, 57

- visualization 9
 - accuracy 44
 - color table 74, 77

 Volume Maximum, evaluating 48, 79, 81

- von Mises stress 43, 109

W Windows list 43, 139

wizard

- New Form 82

workflow 26

Y yield stress 30, 45

Z zoom 123

Zoom Extents command 89